



City of Flint, Michigan

Third Floor, City Hall
1101 S. Saginaw Street
Flint, Michigan 48502
www.cityofflint.com

Meeting Agenda – AMENDED

Monday, March 10, 2025

5:30 PM

AGENDA AMENDED to Add Presentation of Minutes

City Council Chambers

CITY COUNCIL

Ladel Lewis, President, Ward 2
Candice Mushatt, Vice President, Ward 7

Leon El-Alamin, Ward 1
Judy Priestley, Ward 4
Tonya Burns, Ward 6

VACANT, Ward 3
Jerri Winfrey-Carter, Ward 5
Dennis Pfeiffer, Ward 8

Jonathan Jarrett, Ward 9

Davina Donahue, City Clerk

CALL TO ORDER

City Clerk Davina Donahue shall informally call this City Council meeting to order for the purpose of electing a City Council President, in accordance with Section 3-201 (B) of the Flint City Charter.

ROLL CALL

ORGANIZATION OF THE CITY COUNCIL (Council President)

The City Council shall elect from its members a presiding officer who shall be known as the President of the Council

CALL TO ORDER (President-Elect)

The President-Elect shall formally call this City Council meeting to order.

ORGANIZATION OF THE CITY COUNCIL (Council Vice President)

The City Council shall elect from its members an officer who shall be known as the Vice President of the Council.

ORGANIZATION OF THE CITY COUNCIL (Other Officers and Committees)

The City Council may elect such other officers as it deems necessary.

The President-Elect of the City Council may appoint committee officers (Finance, Legislative, and Governmental Operations) and sub-committees as deemed necessary.

PLEDGE OF ALLEGIANCE

PRAYER OR BLESSING

READING OF DISORDERLY PERSONS CITY CODE SUBSECTION

Any person that persists in disrupting this meeting will be in violation of Flint City Code Section 31-10, Disorderly Conduct, Assault and Battery, and Disorderly Persons, and will be subject to arrest for a misdemeanor. Any person who prevents the peaceful and orderly conduct of any meeting will be given one warning. If they persist in disrupting the meeting, that individual will be subject to arrest. Violators will be removed from the meetings.

REQUEST FOR AGENDA CHANGES/ADDITIONS

PUBLIC HEARINGS

240426.6 Public Hearing/Ordinance No. 240426.2/Fair Chance Access to Rental Housing

A Public Hearing to consider Ordinance No. 240426.2, an amended ordinance to amend the Flint City Code of Ordinances by amending Chapter 24, Housing, by the addition of Article IV, Fair Chance Access to Rental Housing, Sections 24-114 to 24-127.

240430.6 Public Hearing/Ordinance No. 240430.1/Community Benefits Agreements

A Public Hearing to consider Ordinance No. 240430.1, an amended ordinance to amend the Flint City Code of Ordinances by amending Chapter 25, Community Development, by the addition of Article I, Community Benefits Agreement.

PUBLIC COMMENT

Members of the public who wish to address the City Council or its committees must register before the meeting begins. A box will be placed at the entrance to the Council Chambers for collection of registrations. No additional speakers or slips will be accepted after the meeting begins.

Members of the public shall have no more than three (3) minutes per speaker during public comment, with only one speaking opportunity per speaker.

COUNCIL RESPONSE

Councilmembers may respond once to all public speakers only after all public speakers have spoken. An individual Councilmember's response shall be limited to two (2) minutes.

RECONSIDERATION (Resolutions)

240548-T Reallocation of ARPA Funds/St. Mark Missionary Baptist Church/Community Outreach Center/Food Access and Food Support System

Resolution resolving that the appropriate City Officials are authorized to do all things necessary, including executing any necessary agreements, to appropriate \$50,000.00 in funding to St Mark Baptist Church's Community Outreach Center [to provide Food Access and Food System Support for the residents of Flint]. Before the funds are spent, the City of Flint's ARPA administration,

compliance, and implementation firm shall review and ensure compliance with the latest US Department of Treasury final rules.

CONSENT AGENDA

Per the amended Rules Governing Meetings of the Flint City Council (as adopted by the City Council on Monday, April 22, 2024), the Chair may request the adoption of a "Consent Agenda". After a motion to adopt a Consent Agenda is made and seconded, the Chair shall ask for separations. Any agenda item on a Consent Agenda shall be separated at the request of any Councilmember. After any separations, there is no debate on approving the Consent Agenda — it shall be voted on or adopted without objection.

PRESENTATION OF MINUTES

250065-T DRAFT/PROPOSED Summary Minutes/Flint City Council/Special Meeting/February 5, 2025

DRAFT/PROPOSED Summary Minutes of the Flint City Special Meeting held Wednesday, February 5, 2025, at 4:54 p.m., in the Council Chambers, 3rd Floor, City Hall.

250066-T DRAFT/PROPOSED Summary Minutes/Flint City Council/Finance Committee Meeting/February 5, 2025

DRAFT/PROPOSED Summary Minutes of the Flint City Finance Committee Meeting held Wednesday, February 5, 2025, at 6:21 p.m., in the Council Chambers, 3rd Floor, City Hall.

250067-T DRAFT/PROPOSED Summary Minutes/Flint City Council/Legislative Committee Meeting/February 5, 2025

DRAFT/PROPOSED Summary Minutes of the Flint City Legislative Committee Meeting held Wednesday, February 5, 2025, at 7:43 p.m., in the Council Chambers, 3rd Floor, City Hall.

250068-T DRAFT/PROPOSED Summary Minutes/Flint City Council/Governmental Operations Committee Meeting/February 5, 2025

DRAFT/PROPOSED Summary Minutes of the Flint City Governmental Operations Committee Meeting held Wednesday, February 5, 2025, at 8:54 p.m., in the Council Chambers, 3rd Floor, City Hall.

250069-T DRAFT/PROPOSED Summary Minutes/Flint City Council/Special Affairs Committee Meeting/February 10, 2025

DRAFT/PROPOSED Summary Minutes of the Flint City Special Affairs Committee Meeting held Monday, February 10, 2025, at 4:40 p.m., in the Council Chambers, 3rd Floor, City Hall.

250070-T DRAFT/PROPOSED Summary Minutes/Flint City Council/Regular Meeting/February 10, 2025

DRAFT/PROPOSED Summary Minutes of the Flint City Regular Meeting held Monday, February 10, 2025, at 6:18 p.m., in the Council Chambers, 3rd Floor, City Hall.

250071-T DRAFT/PROPOSED Summary Minutes/Flint City Council/Special Meeting/February 17, 2025

DRAFT/PROPOSED Summary Minutes of the Flint City Special Meeting held Monday, February 17, 2025, at 5:09 p.m., in the Council Chambers, 3rd Floor, City Hall.

250072-T DRAFT/PROPOSED Summary Minutes/Flint City Council/Finance Committee Meeting/February 19, 2025

DRAFT/PROPOSED Summary Minutes of the Flint City Finance Committee Meeting held Wednesday, February 19, 2025, at 5:08 p.m., in the Council Chambers, 3rd Floor, City Hall.

250073-T DRAFT/PROPOSED Summary Minutes/Flint City Council/Governmental Operations Committee Meeting/February 19, 2025

DRAFT/PROPOSED Summary Minutes of the Flint City Governmental Operations Committee Meeting held Wednesday, February 19, 2025, at 6:05 p.m., in the Council Chambers, 3rd Floor, City Hall.

250074-T DRAFT/PROPOSED Summary Minutes/Flint City Council/Legislative Committee Meeting/February 19, 2025

DRAFT/PROPOSED Summary Minutes of the Flint City Legislative Committee Meeting CANCELLED Wednesday, February 19, 2025, in the Council Chambers, 3rd Floor, City Hall.

250075-T DRAFT/PROPOSED Summary Minutes/Flint City Council/Special Affairs Committee Meeting/February 24, 2025

DRAFT/PROPOSED Summary Minutes of the Flint City Special Affairs Committee Meeting held Monday, February 24, 2025, at 4:44 p.m., in the Council Chambers, 3rd Floor, City Hall.

250076-T DRAFT/PROPOSED Summary Minutes/Flint City Council/Regular Meeting/February 24, 2025

DRAFT/PROPOSED Summary Minutes of the Flint City Regular Meeting held Monday, February 24, 2025, at 5:30 p.m., in the Council Chambers, 3rd Floor, City Hall.

250077-T DRAFT/PROPOSED Summary Minutes/Flint City Council/Finance Committee Meeting/March 5, 2025

DRAFT/PROPOSED Summary Minutes of the Flint City Finance Committee Meeting held Wednesday, March 5, 2025, at 5:06 p.m., in the Council Chambers, 3rd Floor, City Hall.

250078-T DRAFT/PROPOSED Summary Minutes/Flint City Council/Governmental Operations Committee Meeting/March 5, 2025

DRAFT/PROPOSED Summary Minutes of the Flint City Governmental Operations Committee Meeting held Wednesday,

March 5, 2025, at 6:51 p.m., in the Council Chambers, 3rd Floor, City Hall.

250079-T DRAFT/PROPOSED Summary Minutes/Flint City Council/Legislative Committee Meeting/March 5, 2025

DRAFT/PROPOSED Summary Minutes of the Flint City Legislative Committee Meeting CANCELLED Wednesday, March 5, 2025, in the Council Chambers, 3rd Floor, City Hall.

RESOLUTIONS

250058-T State of Michigan's MCOLES/Public Safety Academy Assistance Program/Flint Police Department

Resolution resolving that the appropriate City Officials, upon the City Council approval, are authorized to do all things necessary to accept the program funds set forth in the program agreement of the State of Michigan in the amount of \$138,133.45, amend the FY25 budget, appropriate award funding to appropriate revenue and expenditure in future years as long as funds are available from the funder, and abide by the terms and conditions of the award from the State of Michigan. [NOTE: The State of Michigan has awarded the City of Flint Basic Law Enforcement Training Academy Scholarships and salaries for employed recruits.]

250059-T Tri County International Truck, Inc./2025 Truck Chassis

Resolution resolving that The Division of Purchases and Supplies, upon City Council's approval, is hereby authorized to issue a Purchase Order to Tri County International Trucks, Inc. for the purchase of a 2025 International truck chassis, in amount NOT-TO-EXCEED \$151,079.92, for FY25 (07/01/24-06/30/2025). [NOTE: This truck will replace the 1991 International semi-truck that the Sewer Department currently uses, as the current vehicle no longer makes fiscal sense due to its condition and age.]

RESOLUTIONS (May Be Reconsidered)

240548-T Reallocation of ARPA Funds/St. Mark Missionary Baptist Church/Community Outreach Center/Food Access and Food Support System

Resolution resolving that the appropriate City Officials are authorized to do all things necessary, including executing any necessary agreements, to appropriate \$50,000.00 in funding to St Mark Baptist Church's Community Outreach Center [to provide Food Access and Food System Support for the residents of Flint]. Before the funds are spent, the City of Flint's ARPA administration, compliance, and implementation firm shall review and ensure compliance with the latest US Department of Treasury final rules.

SECOND READING AND ENACTMENT OF ORDINANCES

240426.2-T 2nd Amendment/Ordinance/Code Amendment/Ordinance/Chapter (Housing)/Article IV (Fair Chance Access to Rental Housing)/Sections 24-114 to 24-127

A 2nd amendment to an ordinance to amend the Flint City Code of Ordinances by amending Chapter 24, Housing, by the addition of Article IV, Fair Chance Access to Rental Housing, Sections 24-114 to 24-127. [NOTE: This ordinance to become effective 30 days after adoption.]. [NOTE: Ordinance amended to add specific information under Section 24-119(B)(2) with regard to criminal sexual conduct.] [NOTE: Second amendment to the ordinance is to change some adverse action or conviction dates from 10 and/or 5 years to 3 years.]

240430.1-T Amended Ordinance/Code Amendment/Ordinance/Chapter 25 (Community Development)/Article I (Community Benefits Agreements)/Sections 25-1 to 25-7

An amended ordinance to amend the Flint City Code of Ordinances by amending Chapter 25, Community Development, by the addition of Article I, Community Benefits Agreements. [NOTE: This Ordinance to become effective 30 days after adoption.].

[NOTE: Ordinance amended to add Developer definition information, Tier Project estimations and public hearing details, agreement specifications, and community engagement processes.

CONSIDERATION OF APPLICANTS (CANDIDATES) - 3RD WARD COUNCILMEMBER

Consideration of Applicants/Candidates Regarding the Vacancy in the Office of 3rd Ward Council Member, per Flint City Charter Section 2-410(B).

CURRENT APPLICANTS/CANDIDATES:

1. Beverly L. Biggs-Leavy
2. AC Dumas
3. Richard F. Jones
4. Kerry L. Nelson

This Consideration of Applicants will continue for a total of thirty (30) rounds of council members' roll call votes for candidates. By the 15th round, if the council body has not reached a majority vote for any one candidate, each council member will be allowed three (3) minutes in total to discuss their reasoning for supporting or opposing each candidate. The consideration roll call will then continue until the 30th round.

FINAL COUNCIL COMMENTS

Final Council Comments shall be limited to two (2) minutes.

ADJOURNMENT

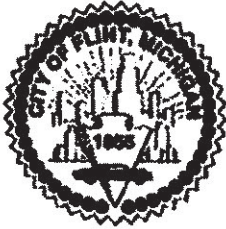

RESOLUTION NO.: 240548-T

PRESENTED: 12-4-2024

ADOPTED: _____

RESOLUTION TO REALLOCATE \$50,000.00 OF ARPA FUNDING TO ST. MARK MISSIONARY BAPTIST CHURCH'S COMMUNITY OUTREACH CENTER FOR FOOD ACCESS AND FOOD SUPPORT SYSTEM

BY THE CITY COUNCIL:

WHEREAS, The City of Flint received funds pursuant to the American Rescue Plan Act of 2021 (ARPA), which could be utilized by the City for defined purposes. In 2023, the City of Flint obligated all of ARPA funding received, of which approximately \$40 million was obligated as "revenue replacement"; and

WHEREAS, City Administration recommends reallocating \$50,000.00 in ARPA funding, previously obligated for revenue replacement, to provide funding to St. Mark Missionary Baptist Church; and

WHEREAS, The funding is to be utilized by St. Mark Missionary Baptist Church for their Community Outreach Center in providing Food Access and Food System Support for the residents of Flint; therefore

Funding is to come from the following account:

Account Number	Account Name	Subrecipient	Amount
101-612.004-801.000	General Fund	St. Mark Missionary Baptist Church	\$50,000.00

IT IS RESOLVED that the appropriate City Officials are hereby authorized to do all things necessary, including executing any necessary agreements, to appropriate \$50,000.00 in funding to St. Mark Missionary Baptist Church's Community Outreach Center. Before the funds are spent, the City of Flint's ARPA administration, compliance, and implementation firm shall review and ensure compliance with the latest US Department of Treasury final rules.

For the City:

For the City Council:

CLYDE D EDWARDS / A0344
CLYDE D EDWARDS / A0344 (Nov 22, 2024 14:19 EST)
Clyde D. Edwards, City Administrator

Approved as to Form:

Approved as to Finance:

J Kuptz
Joseph Kuptz (Nov 22, 2024 12:07 EST)
Joseph Kuptz, Acting City Attorney

Phillip Moore
Phillip Moore (Nov 22, 2024 10:40 EST)
Phillip Moore, Chief Financial Officer



CITY OF FLINT

** STAFF REVIEW FORM **

October 9, 2024

TODAY'S DATE: November 12, 2024

BID/PROPOSAL#: N/A

AGENDA ITEM TITLE: Resolution Approving Reallocation of ARPA Funds to St. Mark Missionary Baptist Church's Community Outreach Center

PREPARED BY: Emily Doerr

VENDOR NAME: St. Mark Missionary Baptist Church

Section I: BACKGROUND/SUMMARY OF PROPOSED ACTION:

St. Mark Missionary Baptist Church's Community Center Outreach program will provide local families with supplemental food access to Flint residents with limited resources and opportunities. The Community Center Outreach program will allow the citizens to have a choice in selecting their food options, which reduces waste and gives dignity back to the individuals and families in need of this resource.

Section II: PREVIOUS ALLOCATIONS (INCLUDE ALL ACCOUNTS USED FOR THIS PURPOSE)/ PROVIDE RESOLUTION OR CONTRACT INFORMATION THAT APPLIES

Fiscal Year	Account	FY GL Allocation	FY PO Amount	FY Expensed	Resolution
2021	296-649.700-880.100 FHHS17ReCAST	\$5,000.00	\$5,000.00	\$5,000.00	N/A

No previous allocations have been made to St. Marks for their food pantry program. The only funds given to them by the city are listed ReCAST Grant (Mental Health Services) for \$5,000.00, which has been fully expended.

Section III:



CITY OF FLINT

**** STAFF REVIEW FORM ****

October 9, 2024

PRE-ENCUMBERED? YES NO REQUISITION NO:

ACCOUNTING APPROVAL: *[Signature]* Date: 11/22/2024

WILL YOUR DEPARTMENT NEED A CONTRACT? YES NO

Section V: RESOLUTION DEFENSE TEAM:

(Place the names of those who can defend this resolution at City Council)

	NAME	PHONE NUMBER
1	Carl Davis	carldavis1c21@aol.com
2	Jordan Brown – SIPI	810.240.4804
3		

STAFF RECOMMENDATION: (PLEASE SELECT): APPROVED NOT APPROVED

DEPARTMENT HEAD SIGNATURE: *[Signature]*
Emily Dower (Nov 22, 2024 12:38 EST)
(Name, Title)

ADMINISTRATION APPROVAL: CLYDE D EDWARDS / A0344
CLYDE D EDWARDS / A0344 (Nov 22, 2024 14:19 EST)
(for \$20,000 or above spending authorizations)

250065-T



City of Flint, Michigan

Third Floor, City Hall
1101 S. Saginaw Street
Flint, Michigan 48502
www.cityofflint.com

Meeting Minutes – FINAL

Wednesday, February 5, 2025

4:54 PM

City Council Chambers

SPECIAL CITY COUNCIL

Ladel Lewis, President, Ward 2

Candice Mushatt, Vice President, Ward 7

Leon El-Alamin, Ward 1

VACANT, Ward 3

Judy Priestley, Ward 4

Jerri Winfrey-Carter, Ward 5

Tonya Burns, Ward 6

Dennis Pfeiffer, Ward 8

Jonathan Jarrett, Ward 9

Davina Donahue, City Clerk

*This Special City Council Meeting was called by Vice President Candice Mushatt and Finance Chairperson Judy Priestley for the following purpose(s): To Consider Applicants/Candidates Regarding the Vacancy in the Office of Third (3rd) Ward Council Member, per Flint City Charter Section 2-410(B), with Specified Parameters**(**Specified Parameters – This Special Council Meeting will continue for a total of thirty (30) rounds of council member' roll call votes for candidates or one (1) hour – whichever comes first. By the fifteenth (15th) round, if the council body has not reached a majority vote for any one candidate, each council member will have three (3) minutes in total to discuss their reasoning for supporting or opposing each candidate. The meeting will then continue until the specified ending time or 30th round.**)*

CALL TO ORDER

Vice President Mushatt Called this Special City Council Meeting to Order at 4:54 p.m.

ROLL CALL

Present: Councilmembers El-Alamin, Lewis, Priestley, Winfrey-Carter, Burns, Mushatt, Pfeiffer, and Jarrett

(Councilmember Lewis arrived in her seat just after Roll Call, at approximately 4:58 p.m. Councilmember Burns arrived in her seat during Public Comment, at approximately 5:06 p.m.)

PLEDGE OF ALLEGIANCE

Led by Councilmember Winfrey-Carter

PRAYER OR BLESSING

Prayer or Blessing led by Councilmember El-Alamin

READING OF DISORDERLY PERSON CITY CODE SUBSECTION

Read Into Record

PUBLIC COMMENT

4 Public Speakers

COUNCIL RESPONSE

NONE

CONSIDERATION OF APPLICANTS (CANDIDATES) – 3RD WARD COUNCILMEMBER

Consideration of Applicants/Candidates Regarding the Vacancy in the Office of 3rd Ward Council Member, per Flint City Charter Section 2-410(B)(1).

CURRENT APPLICANTS/CANDIDATES:

1. *Beverly L. Biggs-Leavy*
2. *AC Dumas*
3. *Richard F. Jones*
4. *Kerry L. Nelson*

If the remaining meeting time permits, council member roll call votes for candidates will proceed for a total of thirty (30) rounds. By the fifteenth (15th) round, if the council body has not reached a majority vote for any one

candidate, each council member will have three (3) minutes in total to discuss their reasoning for supporting or opposing each candidate. The meeting will then continue until the thirtieth (30th) round or the specified meeting ending time of one hour from the Call to Order (approximately 5:45 p.m.).

Rounds proceeded as follows:

ROUND #1

- El-Alamin @ Jones
- Lewis @ NOT IN
- Priestley @ Nelson
- Winfrey-Carter @ Biggs-Leavy
- Burns @ Biggs-Leavy
- X Mushatt @ Nelson
- Pfeiffer @ Dumas
- Jarrett @ Biggs-Leavy

ROUND #2

- El-Alamin @ Jones
- Lewis @ NOT IN
- Priestley @ Nelson
- Winfrey-Carter @ Biggs-Leavy
- Burns @ Biggs-Leavy
- Mushatt @ Nelson
- X Pfeiffer @ Dumas
- Jarrett @ Biggs-Leavy

ROUND #3

- El-Alamin @ Nelson
- Lewis @ NOT IN
- Priestley @ Nelson
- Winfrey-Carter @ Biggs-Leavy
- Burns @ Biggs-Leavy

- Mushatt @ Nelson
- Pfeiffer @ Dumas
- X Jarrett @ Biggs-Leavy

ROUND #4

- X El-Alamin @ Nelson
- Lewis @ NOT IN
- Priestley @ Nelson
- Winfrey-Carter @ Biggs-Leavy
- Burns @ Biggs-Leavy
- Mushatt @ Nelson
- Pfeiffer @ Dumas
- Jarrett @ Biggs-Leavy

ROUND #5

- El-Alamin @ Nelson
- X Lewis @ ABSENT
- Priestley @ Nelson
- Winfrey-Carter @ Biggs-Leavy
- Burns @ Biggs-Leavy
- Mushatt @ Nelson
- Pfeiffer @ Dumas
- Jarrett @ Biggs-Leavy

ROUND #6

- El-Alamin @ Nelson
- Lewis @ ABSENT
- X Priestley @ Nelson
- Winfrey-Carter @ Biggs-Leavy
- Burns @ Biggs-Leavy

- Mushatt @ Nelson
- Pfeiffer @ Dumas
- Jarrett @ Biggs-Leavy

ROUND #7

- El-Alamin @ Nelson
- Lewis @ ABSENT
- Priestley @ Nelson
- Winfrey-Carter @ Biggs-Leavy
- Burns @ Biggs-Leavy
- Mushatt @ Nelson
- Pfeiffer @ Dumas
- Jarrett @ Biggs-Leavy

ROUND #8

- El-Alamin @ Jones
- Lewis @ ABSENT
- Priestley @ Nelson
- Winfrey-Carter @ Biggs-Leavy
- Burns @ Biggs-Leavy
- Mushatt @ Nelson
- Pfeiffer @ Dumas
- Jarrett @ Biggs-Leavy

ROUND #9

- El-Alamin @ Nelson
- Lewis @ ABSENT
- Priestley @ Nelson
- Winfrey-Carter @ Biggs-Leavy
- Burns @ Biggs-Leavy
- Mushatt @ Nelson

- Pfeiffer @ Dumas
- Jarrett @ Biggs-Leavy

ROUND #10

- El-Alamin @ Nelson
- Lewis @ ABSENT
- Priestley @ Nelson
- Winfrey-Carter @ Biggs-Leavy
- Burns @ Biggs-Leavy
- Mushatt @ Nelson
- X Pfeiffer @ Dumas
- Jarrett @ Biggs-Leavy

ROUND #11

- El-Alamin @ Nelson
- Lewis @ ABSENT
- Priestley @ Nelson
- Winfrey-Carter @ Biggs-Leavy
- Burns @ Biggs-Leavy
- Mushatt @ Nelson
- Pfeiffer @ Dumas
- X Jarrett @ Biggs-Leavy

ROUND #12

- X El-Alamin @ Dumas
- Lewis @ ABSENT
- Priestley @ Nelson
- Winfrey-Carter @ Biggs-Leavy
- Burns @ Biggs-Leavy
- Mushatt @ Nelson

- Pfeiffer @ Dumas
- Jarrett @ Biggs-Leavy

ROUND #13

- El-Alamin @ Jones
- Lewis @ ABSENT
- Priestley @ Nelson
- Winfrey-Carter @ Biggs-Leavy
- Burns @ Biggs-Leavy
- Mushatt @ Nelson
- Pfeiffer @ Dumas
- Jarrett @ Biggs-Leavy

ROUND #14

- El-Alamin @ Nelson
- Lewis @ ABSENT
- Priestley @ Nelson
- Winfrey-Carter @ Biggs-Leavy
- Burns @ Biggs-Leavy
- Mushatt @ Nelson
- Pfeiffer @ Dumas
- Jarrett @ Biggs-Leavy

ROUND #15

- El-Alamin @ Nelson
- Lewis @ ABSENT
- Priestley @ Nelson
- Winfrey-Carter @ Biggs-Leavy
- Burns @ Biggs-Leavy
- Mushatt @ Nelson

- Pfeiffer @ Dumas
- Jarrett @ Biggs-Leavy

DISCUSSION

By the fifteenth (15th) round, if the council body has not reached a majority vote for any one candidate, each council member will have three (3) minutes in total to discuss their reasoning for supporting or opposing each candidate.

HELD

ROUND #16

- El-Alamin @ Biggs-Leavy Nelson
- Lewis @ Nelson
- Priestley @ Nelson
- Winfrey-Carter @ Biggs-Leavy
- Burns @ Biggs-Leavy
- Mushatt @ Nelson
- Pfeiffer @ Dumas Biggs-Leavy
- Jarrett @ Biggs-Leavy

ADJOURNMENT

Councilmember Pfeiffer, seconded by Councilmember Priestley, made a motion to Adjourn. This Special Meeting Adjourned at 6:03 p.m.

This Motion PASSED by a VOTE of 6:1 (No: Lewis)

Absent (Jarrett)

Respectfully transcribed and submitted,

*Jasmine Green
City Council Secretary*

250066-T



City of Flint, Michigan

Third Floor, City Hall
1101 S. Saginaw Street
Flint, Michigan 48502
www.cityofflint.com

Meeting Minutes – FINAL

Wednesday, February 5, 2025
6:21 PM

City Council Chambers

FINANCE COMMITTEE

Judy Priestley, Chairperson, Ward 4

Leon El-Alamin, Ward 1

VACANT, Ward 3

Tonya Burns, Ward 6

Dennis Pfeiffer, Ward 8

Ladel Lewis, Ward 2

Jerri Winfrey-Carter, Ward 5

Candice Mushatt, Ward 7

Jonathan Jarrett, Ward 9

Davina Donahue, City Clerk

ROLL CALL

Present: Councilmembers El-Alamin, Lewis, Priestley, Winfrey-Carter, Burns, Mushatt, Pfeiffer and Jarrett

(Councilmember Burns arrived in her seat at approximately 6:23 p.m. just after Roll Call)

REQUEST FOR AGENDA CHANGES/ADDITIONS

Chairperson Priestley ordered without objection to put two add-ons at the end of Agenda. Add-on #1-\$50,000 to Bethel Methodist Church and Add-on #2-Grant for HUD Lead-Based Hazard Control.

PUBLIC COMMENT

COUNCIL RESPONSE

Councilmembers to respond (Burns, El-Alamin, Lewis, Mushatt, and Priestley)

CONSENT AGENDA

RESOLUTIONS

250033-T Grant Acceptance/Energy Efficiency and Conservation Block Grant/Purchase EV Charging Stations

Resolution resolving that the appropriate City officials are authorized to do all things necessary to accept the grant funds and amend the FY25 budget set forth in the grant from the United States Department of Energy in the amount of up to \$144,050.00 to appropriate revenue and expenditure amounts and to make the grant funds available from January 1st, 2025 through December 31st, 2025. AND, further resolving that the division of purchases and supplies is hereby authorized to issue a purchase order to for a total NOT-TO-EXCEED the amount of \$92,233.00 to Weinstein Electric Company.

SEPARATED FROM THE MASTER RESOLUTION

250034-T Budget Amendment/Second Quarter 2025

Resolution resolving that the appropriate officials are hereby authorized to do all things necessary to incorporate the approved appropriation changes into the FY 2025 operating budget of the City of Flint.

This Matter PASSED on the Consent Agenda

250035-T Contract/Genesee Health System/Flint RECAST Community Based Trainings

Resolution resolving that the appropriate City Officials are authorized to do all things necessary to enter into a contract with Genesee Health System in the amount NOT-TO-EXCEED \$153,755.00.

This Matter PASSED on the Consent Agenda

250040-T Dearborn Life Insurance Company/Provider of Life and Short-Term Disability Insurance

Resolution resolving that the appropriate officials are hereby authorized to do all things necessary to enter into an agreement with Dearborn National Life Insurance Company to continue providing the City with its short-term disability and life insurance coverage for the remainder of FY2025 for the amount of \$70,000.00, and \$140,000 for the period July 1, 2025-March 1, 2026, pending adoption of the FYE2026 budget, for a total amount not to exceed \$210,000.00.

This Matter PASSED on the Consent Agenda

ADD-ON #1 Reallocation of ARPA Funds/Bethel United Methodist Church/Food Pantry/Food Access and Food Support System

Resolution resolving that the appropriate City Officials are hereby authorized to do all things necessary, including executing any necessary agreements, to appropriate \$50,000.00 in funding to Bethel United Methodist Church for their Food Pantry program. Before the funds are spent, the City of Flint's ARPA administration, compliance, and implementation firm shall review and ensure compliance with the latest US Department of Treasury final rules.

SEPARATED FROM THE MASTER RESOLUTION

ADD-ON #2 Grant Acceptance/The Department of Housing and Urban Development (HUD) Lead-Based Paint Hazard Control/Amend 2024-25 Budget

Resolution resolving that the appropriate City Officials are authorized to do all things necessary to, accept the Lead-Based Paint and Hazard Control grant, amend the 2024-25 budget, appropriate grant funding for revenue and expenditures in future fiscal years as long as funds are available from the funder, and abide by the terms and conditions of the grant from The Department of Housing and Urban Development, in the amount NOT-TO-EXCEED \$3,059,006.68 over the 48-month grant period, from November 15, 2024-November 15, 2028.

This Matter PASSED on the Consent Agenda

CONSENT AGENDA VOTE

Councilmember Lewis, seconded by Councilmember El-Alamin, made a motion to Approve the Consent Agenda with any separations (Reso. # 250034-T, 250035-T, 250040-T, and Add-On # 2 are a part of the Consent Agenda [SENT TO COUNCIL]). This Motion PASSED by the following vote:

Aye: 8 – Councilmember El-Alamin, Councilmember Lewis, Councilmember Priestley, Councilmember Winfrey-Carter, Councilmember Burns, Councilmember Mushatt, Councilmember Pfeiffer, and Councilmember Jarrett

No: 0 –

SEPARATED FROM MASTER RESOLUTION (CONSENT AGENDA)

250033-T Grant Acceptance/Energy Efficiency and Conservation Block Grant/Purchase EV Charging Stations

Resolution resolving that the appropriate City officials are authorized to do all things necessary to accept the grant funds and amend the FY25 budget set forth in the grant from the United States Department of Energy in the amount of up to \$144,050.00 to appropriate revenue and expenditure amounts and to make the grant funds available from January 1st, 2025 through December 31st, 2025. AND, further resolving that the division of purchases and supplies is hereby authorized to issue a purchase order to for a total NOT-TO-EXCEED the amount of \$92,233.00 to Weinstein Electric Company.

**A motion was made by Councilmember Mushatt, seconded by Councilmember El-Alamin, that this matter be sent to COUNCIL (2-10-2025). This motion PASSED by the following vote:*

Aye: 7 – Councilmember Lewis, Councilmember Winfrey-Carter, Councilmember Burns, Councilmember Mushatt, Councilmember Pfeiffer, Councilmember Jarrett, and Councilmember El-Alamin

No: 1 – Councilmember Priestley

ADD-ON #1 Reallocation ARPA Funds/Bethel United Methodist Church's Food Pantry/Food Access and Food Support System

Resolution resolving that the appropriate City Officials are hereby authorized to do all things necessary, including executing any necessary agreements, to appropriate \$50,000.00 in funding to Bethel United Methodist Church for their Food Pantry program. Before the funds are spent, the City of Flint's ARPA administration, compliance, and implementation firm shall review and ensure compliance with the latest US Department of Treasury final rules.

**A motion was made by Councilmember Burns, seconded by Councilmember Winfrey-Carter, that this matter be sent to COUNCIL (2-10-2025). No Votes were Taken.*

**A motion was made by Councilmember Lewis, seconded by Councilmember Priestley, that this matter stay in FINANCE COMMITTEE. This motion FAILED by the following vote:*

Aye: 2 – Councilmember Priestley, and Councilmember Lewis

No: 6 – Councilmember Winfrey-Carter, Councilmember Burns, Councilmember Mushatt, Councilmember Pfeiffer, Councilmember Jarrett, and Councilmember El-Alamin

**A motion was made by Councilmember Mushatt, seconded by Councilmember El-Alamin, that this matter be sent to SPECIAL AFFAIRS COMMITTEE (2-10-2025). This motion PASSED by the following vote:*

Aye: 8 – Councilmember Winfrey-Carter, Councilmember Burns, Councilmember Mushatt, Councilmember Pfeiffer, Councilmember Jarrett, Councilmember El-Alamin, Councilmember Lewis, and Councilmember Priestley

No: 0 –

ADJOURNMENT

Councilmember Pfeiffer, seconded by Councilmember Mushatt, made a motion to Adjourn. This Finance Committee Meeting Adjourned at 7:38 p.m.

This Motion PASSED by a VOTE of 8:0

Respectfully transcribed and submitted,

*Jasmine Green
City Council Secretary*



250067-T

City of Flint, Michigan

Third Floor, City Hall
1101 S. Saginaw Street
Flint, Michigan 48502
www.cityofflint.com

Meeting Minutes – FINAL

Wednesday February 5, 2025

7:43 PM

City Council Chambers

LEGISLATIVE COMMITTEE

VACANT, Chairperson

- | | |
|------------------------------|-------------------------|
| Leon El-Alamin, Ward 1 | Ladel Lewis, Ward 2 |
| VACANT, Ward 3 | Judy Priestley, Ward 4 |
| Jerri Winfrey-Carter, Ward 5 | Tonya Burns, Ward 6 |
| Candice Mushatt, Ward 7 | Dennis Pfeiffer, Ward 8 |
| Jonathan Jarrett, Ward 9 | |
| Davina Donahue, City Clerk | |

ROLL CALL

Present: Councilmembers El-Alamin, Lewis, Priestley, Winfrey-Carter, Burns, Mushatt, Pfeiffer and Jarrett

(Councilmember Jarrett arrived in his seat just after Roll Call at approximately 7:45 p.m., Councilmember El-Alamin arrived at approximately 7:46 p.m. just after Roll Call, and Councilmember Priestley arrived in her seat during Public Comment, at approximately 7:58 p.m.)

REQUEST FOR AGENDA CHANGES/ADDITIONS

Clerk Donahue stated that there is a proposed amended version of Ordinance 240426.1 (Fair Chance Access to Rental Housing).

PUBLIC COMMENT

6 Public Speakers

COUNCIL RESPONSE

Councilmembers to respond (El-Alamin, Burns, Winfrey-Carter, Lewis, and Mushatt)

CONSENT AGENDA

ORDINANCES

240426.1-T Amended Ordinance/Code Amendment/Ordinance/Chapter 24 (Housing)/Article IV (Fair Chance Access to Rental Housing)/Sections 24-114 to 24-127

An amended ordinance to amend the Flint City Code of Ordinances by amending Chapter 24, Housing, by the addition of Article IV, Fair Chance Access to Rental Housing, Sections 24-114 to 24-127. [NOTE: This ordinance to become effective 30 days after adoption.]. [NOTE: ordinance amended to add specific information under Section 24-119(B)(2) with regard to criminal sexual conduct.]

SEPARATED FROM THE MASTER RESOLUTION

240430.1-T Amended Ordinance/Code Amendment/Ordinance/Chapter 25 (Community Development)/Article I (Community Benefits Agreements)/Sections 25-1 to 25-7

An amended ordinance to amend the Flint City Code of Ordinances by amending Chapter 25, Community Development, by the addition of Article I, Community Benefits Agreements. [NOTE: This ordinance to become effective 30 days after adoption.]. [NOTE: Ordinance amended to add Developer definition information, Tier Project estimations and public hearing details, agreement specifications, and community engagement processes.]

SEPARATED FROM THE MASTER RESOLUTION

CONSENT AGENDA VOTE

Councilmember Priestley, seconded by Councilmember El-Alamin, made a motion to Approve the Consent Agenda with any separations [SEND TO COUNCIL]. Councilmember Pfeiffer requested a total separation. No Votes were taken.

SEPARATED FROM MASTER RESOLUTION (CONSENT AGENDA)

240426.1-T Amended Ordinance/Code Amendment/Ordinance/Chapter 24 (Housing)/Article IV (Fair Chance Access to Rental Housing)/Sections 24-114 to 24-127

An amended ordinance to amend the Flint City Code of Ordinances by amending Chapter 24, Housing, by the addition of Article IV, Fair Chance Access to Rental Housing, Sections 24-114 to 24-127. [NOTE: This ordinance to become effective 30 days after adoption.]. [NOTE: ordinance amended to add specific information under Section 24-119(B)(2) with regard to criminal sexual conduct.]

**A motion was made by Councilmember El-Alamin, that this matter be Amended to 240426.2-T. No Votes were taken.*

**A motion was made by Councilmember Pfeiffer, seconded by Councilmember Priestley, that this matter be sent to COUNCIL (2-10-2025). No Votes were Taken.*

**A motion was made by Councilmember Pfeiffer, seconded by Councilmember El-Alamin, that this matter be Amended to 240426.2-T (Revise Ordinance per Draft received) [NOTE: Ordinance amended to change some adverse action or conviction dates from 10 to 5 years to 3 years.]. This motion PASSED by the following vote:*

Aye: 8 – Councilmember El-Alamin, Councilmember Lewis, Councilmember Priestley, Councilmember Winfrey-Carter, Councilmember Burns, Councilmember Mushatt, Councilmember Pfeiffer, and Councilmember Jarrett

No: 0 –

**A motion was made by Councilmember Pfeiffer, seconded by Councilmember El-Alamin, that Ordinance 240426.2-T be sent to COUNCIL (2-10-2025). This motion PASSED by the following vote:*

Aye: 8 – Councilmember Lewis, Councilmember Priestley, Councilmember Winfrey-Carter, Councilmember Burns, Councilmember Mushatt, Councilmember Pfeiffer, Councilmember Jarrett, and Councilmember El-Alamin

No: 0 –

240430.1-T Amended Ordinance/Code Amendment/Ordinance/Chapter 25 (Community Development)/Article I (Community Benefits Agreements)/Sections 25-1 to 25-7

An amended ordinance to amend the Flint City Code of Ordinances by amending Chapter 25, Community Development, by the addition of Article I, Community Benefits Agreements. [NOTE: This ordinance to become effective 30 days after adoption.]. [NOTE: Ordinance amended to add Developer definition information, Tier Project estimations and public hearing details, agreement specifications, and community engagement processes.]

**A motion was made by Councilmember El-Alamin, seconded by Councilmember Priestley, that this matter be sent to COUNCIL (2-10-2025). No Votes were Taken.*

**A motion was made by Councilmember Winfrey-Carter, seconded by Councilmember Lewis, that this matter be sent to SPECIAL AFFAIRS (2-10-2025). This motion PASSED by the following vote:*

Aye: 6 – Councilmember Priestley, Councilmember Winfrey-Carter, Councilmember Mushatt, Councilmember Jarrett, Councilmember El-Alamin, and Councilmember Lewis

No: 1 – Councilmember Pfeiffer

Absent: Councilmember Burns

ADJOURNMENT

Councilmember Pfeiffer, seconded by Councilmember El-Alamin, made a motion to Adjourn. This Legislative Committee Meeting Adjourned at 8:46 p.m.

This Motion PASSED by a VOTE of 7:0.

Absent (Burns)

Respectfully transcribed and submitted,

*Jasmine Green
City Council Secretary*



250068-T

City of Flint, Michigan

Third Floor, City Hall
1101 S. Saginaw Street
Flint, Michigan 48502
www.cityofflint.com

Meeting Minutes – FINAL

Wednesday, February 5, 2025
8:54 PM

City Council Chambers

GOVERNMENTAL OPERATIONS COMMITTEE

VACANT, Chairperson

Leon El-Alamin, Ward 1

VACANT, Ward 3

Jerri Winfrey-Carter, Ward 5

Candice Mushatt, Ward 7

Jonathan Jarrett, Ward 9

Ladel Lewis, Ward 2

Judy Priestley, Ward 4

Tonya Burns, Ward 6

Dennis Pfeiffer, Ward 8

Davina Donahue, City Clerk

ROLL CALL

Present: Councilmembers El-Alamin, Lewis, Priestley, Winfrey-Carter, Burns, Mushatt, Pfeiffer and Jarrett

(Councilmember Burns arrived in her seat during Public Comment, at approximately 9:00 p.m.)

REQUEST FOR AGENDA CHANGES/ADDITIONS

Vice President Mushatt ordered without objection to accept Add-on #1 – Appointment for Shirley Wilson Johnson to The Board of Review.

PUBLIC COMMENT

3 Public Speakers

COUNCIL RESPONSE

Councilmembers to Respond (Burns, Lewis, and Mushatt)

CONSENT AGENDA

APPOINTMENTS

250037-T Appointment/Community-Wide Advisory Council/Joyce Ellis McNeal/8th Ward

Resolution resolving that the Flint City Council approves the appointment of Joyce Ellis-McNeal, of 4021 Greenbrook Lane, Flint MI 48507, to the 8th Ward seat on the Citywide Advisory Council, to serve a term from March 1, 2025 to February 28, 2028.

SEPARATED FROM THE MASTER RESOLUTION

250038-T Appointment/Flint Planning Commission/Edquan Dantzler/1st Ward

Resolution resolving that the Flint City Council approves the appointment of Edquan N. Dantzler, of 6702 Sally Court, Flint MI 48505, to the 1st Ward seat on the Planning Commission, to serve a term from April 1, 2025 to March 31, 2028.

SEPARATED FROM THE MASTER RESOLUTION

250039-T Appointment/Flint Planning Commission/Rodrick L. Green/3rd Ward

Resolution resolving that the Flint City Council approves the appointment of Rodrick L. Green, of 1183 E. Holbrook Ave., Flint, MI 48505, to the 3rd Ward seat on the Planning Commission, to serve a term from March 1, 2025 to February 28, 2028.

SEPARATED FROM THE MASTER RESOLUTION

ADD-ON #1 Appointment/Board of Review/Shirley Wilson Johnson/9th Ward

Resolution resolving that the Flint City Council approves the appointment of Shirley Wilson Johnson (2715 Lakewood Drive, Flint, Michigan, 48507) as 9th Ward representative, for a three-year term commencing upon adoption of this resolution and expiring December 31, 2028.

SEPARATED FROM THE MASTER RESOLUTION

CONSENT AGENDA VOTE

Councilmember Priestley, seconded by Councilmember Pfeiffer, made a motion to Approve the Consent Agenda with any separations (SEND TO COUNCIL). Councilmember Jarrett requested total separation. No Votes were taken.

SEPARATED FROM MASTER RESOLUTION (CONSENT AGENDA)

250037-T Appointment/Community-Wide Advisory Council/Joyce Ellis McNeal/8th Ward

Resolution resolving that the Flint City Council approves the appointment of Joyce Ellis-McNeal, of 4021 Greenbrook Lane, Flint MI 48507, to the 8th Ward seat on the Citywide Advisory Council, to serve a term from March 1, 2025 to February 28, 2028.

**A motion was made by Councilmember Jarrett, seconded by Councilmember Burns, that this matter be sent to SPECIAL AFFAIRS (2-10-2025). This motion PASSED by the following vote:*

Aye: 8 – Councilmember El-Alamin, Councilmember Lewis, Councilmember Priestley, Councilmember Winfrey-Carter, Councilmember Burns, Councilmember Mushatt, Councilmember Pfeiffer and Councilmember Jarrett

No: 0 –

250038-T Appointment/Flint Planning Commission/Edquan Dantzler/1st Ward

Resolution resolving that the Flint City Council approves the appointment of Edquan N. Dantzler, of 6702 Sally Court, Flint MI 48505, to the 1st Ward seat on the Planning Commission, to serve a term from April 1, 2025 to March 31, 2028.

**A motion was made by Councilmember Pfeiffer, seconded by Councilmember El-Alamin, that this matter be sent to COUNCIL (2-10-2025). This motion PASSED by the following vote:*

Aye: 8 – Councilmember Lewis, Councilmember Priestley, Councilmember Winfrey-Carter, Councilmember Burns, Councilmember Mushatt, Councilmember Pfeiffer, Councilmember Jarrett, and Councilmember El-Alamin

No: 0 –

250039-T Appointment/Flint Planning Commission/Rodrick L. Green/3rd Ward

Resolution resolving that the Flint City Council approves the appointment of Rodrick L. Green, of 1183 E. Holbrook Ave., Flint, MI 48505, to the 3rd Ward seat on the Planning Commission, to serve a term from March 1, 2025 to February 28, 2028.

**A motion was made by Councilmember Jarrett, seconded by Councilmember Burns, that this matter be sent to SPECIAL AFFAIRS (2-10-2025). This motion PASSED by the following vote:*

Aye: 8 – Councilmember El-Alamin, Councilmember Lewis, Councilmember Priestley, Councilmember Winfrey-Carter, Councilmember Burns, Councilmember Mushatt, Councilmember Pfeiffer and Councilmember Jarrett

No: 0 –

ADD-ON #1 Appointment/Board of Review/Shirley Wilson Johnson/9th Ward

Resolution resolving that the Flint City Council approves the appointment of Shirley Wilson Johnson (2715 Lakewood Drive, Flint, Michigan, 48507) as 9th Ward representative, for a three-year term commencing upon adoption of this resolution and expiring December 31, 2028.

**A motion was made by Councilmember Jarrett, seconded by Councilmember Burns, that this matter be sent to SPECIAL AFFAIRS (2-10-2025). This motion PASSED by the following vote:*

Aye: 8 – Councilmember El-Alamin, Councilmember Lewis, Councilmember Priestley, Councilmember Winfrey-Carter, Councilmember Burns, Councilmember Mushatt, Councilmember Pfeiffer and Councilmember Jarrett

No: 0 –

ADJOURNMENT

Councilmember Priestley, seconded by Councilmember Pfeiffer, made a motion to Adjourn. This Governmental Operations Committee Meeting Adjourned at 9:27 p.m.

This Motion PASSED by a VOTE of 8:0

Respectfully transcribed and submitted,

Jasmine Green

City Council Secretary



250069-T

City of Flint, Michigan

Third Floor, City Hall
1101 S. Saginaw Street
Flint, Michigan 48502
www.cityofflint.com

MEETING MINUTES – FINAL

Monday, February 10, 2025

4:40 PM

City Council Chambers

SPECIAL AFFAIRS COMMITTEE

Candice Mushatt, Vice President, Ward 7

Leon El-Alamin, Ward 1

Ladel Lewis, Ward 2

VACANT, Ward 3

Judy Priestley, Ward 4

Jerri Winfrey-Carter, Ward 5

Tonya Burns, Ward 6

Dennis Pfeiffer, Ward 8

Jonathan Jarrett, Ward 9

Davina Donahue, City Clerk

ROLL CALL

Present: Councilmembers El-Alamin, Lewis, Priestley, Winfrey-Carter, Burns, Mushatt, Pfeiffer, and Jarrett

(Councilmember Pfeiffer arrived in his seat at approximately 4:44 p.m., just after Roll Call, Councilmember Lewis arrived in her seat at approximately 4:56 p.m., during Public Comment)

READING OF DISORDERLY PERSON CITY CODE SUBSECTION

Read Into Record

REQUEST FOR AGENDA CHANGES/ADDITIONS

None

PUBLIC COMMENT

11 Public Speakers

COUNCIL RESPONSE

Councilmembers to respond (Priestley, Burns, Winfrey-Carter, El-Alamin, and Lewis)

CONSENT AGENDA

RESOLUTIONS

250042-T Reallocation of ARPA Funds/Bethel United Methodist church's Food Pantry/Food access and Food Support System

Resolution resolving that the appropriate City Officials are hereby authorized to do all things necessary, including executing any necessary agreements, to appropriate \$50,000.00 in funding to Bethel United Methodist Church for their Food Pantry program. Before the funds are spent, the City of Flint's ARPA administration, compliance, and implementation firm shall review and ensure compliance with the latest US Department of Treasury final rules.

SEPARATED FROM THE MASTER RESOLUTION

APPOINTMENTS

250037-T Appointment/Community-Wide Advisory Council/Joyce Ellis McNeal/8th Ward

Resolution resolving that the Flint City Council approves the appointment of Joyce Ellis-McNeal, of 4021 Greenbrook Lane, Flint MI 48507, to the 8th Ward seat on the Citywide Advisory Council, to serve a term from March 1, 2025 to February 28, 2028.

SEPARATED FROM THE MASTER RESOLUTION

250039-T Appointment/Flint Planning Commission/Rodrick L. Green/3rd Ward

Resolution resolving that the Flint City Council approves the appointment of Rodrick L. Green, of 1183 E. Holbrook Ave., Flint, MI 48505, to the 3rd Ward seat on the Planning Commission, to serve a term from March 1, 2025 to February 28, 2028.

SEPARATED FROM THE MASTER RESOLUTION

250041-T Appointment/Board of Review/Shirley Wilson Johnson/9th Ward

Resolution resolving that the Flint City Council approves the appointment of Shirley Wilson Johnson (2715 Lakewood Drive, Flint, Michigan, 48507) as 9th Ward representative, for a three-year term commencing upon adoption of this resolution and expiring December 31, 2028.

SEPARATED FROM THE MASTER RESOLUTION

ORDINANCES

240430.1-T Amended Ordinance/Code Amendment/Ordinance/Chapter25 (Community Development)/Article I (Community Benefits Agreements)/Sections 25-1 to 25-7

An amended ordinance to amend the Flint City Code of Ordinances by amending Chapter 25, Community Development, by the addition of Article I, Community Benefits Agreements. [NOTE: This Ordinance to become effective 30 days after adoption.]. [NOTE: Ordinance amended to add Developer definition information, Tier Project estimations and public hearing details, agreement specifications, and community engagement processes.]

This Matter PASSED on the Consent Agenda

CONSENT AGENDA VOTE

Councilmember Priestley, seconded by Councilmember Pfeiffer, made a motion to Approve the Consent Agenda with any separations (SEND TO COUNCIL), Reso. # 240430.1-T is a part of the Consent Agenda. This Motion PASSED by the following vote:

Aye: 8 – Councilmember El-Alamin, Councilmember Lewis, Councilmember Priestley, Councilmember Winfrey-Carter, Councilmember Burns, Councilmember Mushatt, Councilmember Pfeiffer, and Councilmember Jarrett

No: 0 –

SEPARATED FROM MASTER RESOLUTION (CONSENT AGENDA)

250042-T Reallocation of ARPA Funds/Bethel United Methodist church's Food Pantry/Food access and Food Support System

Resolution resolving that the appropriate City Officials are hereby authorized to do all things necessary, including executing any necessary agreements, to appropriate \$50,000.00 in funding to Bethel United Methodist Church for their Food Pantry program. Before the funds are spent, the City of Flint's ARPA administration, compliance, and implementation firm shall review and ensure compliance with the latest US Department of Treasury final rules.

**A motion was made by Councilmember Mushatt, seconded by Councilmember El-Alamin, that this matter be Sent to COUNCIL. This motion PASSED by the following vote:*

Aye: 8 – Councilmember Lewis, Councilmember Priestley, Councilmember Winfrey-Carter, Councilmember Burns, Councilmember Mushatt, Councilmember Pfeiffer, Councilmember Jarrett, and Councilmember El-Alamin

No: 0 –

250037-T Appointment/Community-Wide Advisory Council/Joyce Ellis McNeal/8th Ward

Resolution resolving that the Flint City Council approves the appointment of Joyce Ellis-McNeal, of 4021 Greenbrook Lane, Flint MI 48507, to the 8th Ward seat on the Citywide Advisory Council, to serve a term from March 1, 2025 to February 28, 2028.

**A motion was made by Councilmember Pfeiffer, seconded by*

Councilmember El-Alamin, that this matter be sent to COUNCIL. No Votes were taken.

**A motion was made by Councilmember Pfeiffer, seconded by Councilmember Winfrey-Carter, that Reso. 250037-T be AMENDED to a .1 to include new Language. This motion PASSED by the following vote:*

Aye: 8 – Councilmember Priestley, Councilmember Winfrey-Carter, Councilmember Burns, Councilmember Mushatt, Councilmember Pfeiffer, Councilmember Jarrett, Councilmember El-Alamin, and Councilmember Lewis

No: 0 –

**A motion was made by Councilmember Pfeiffer, seconded by Councilmember El-Alamin, that AMENDED Reso. 250037.1-T be sent to COUNCIL. This motion PASSED by the following vote:*

Aye: 8 – Councilmember Winfrey-Carter, Councilmember Burns, Councilmember Mushatt, Councilmember Pfeiffer, Councilmember Jarrett, Councilmember El-Alamin, Councilmember Lewis, and Councilmember Priestley

No: 0 –

250039-T Appointment/Flint Planning Commission/Rodrick L. Green/3rd Ward

Resolution resolving that the Flint City Council approves the appointment of Rodrick L. Green, of 1183 E. Holbrook Ave., Flint, MI 48505, to the 3rd Ward seat on the Planning Commission, to serve a term from March 1, 2025 to February 28, 2028.

**A motion was made by Councilmember Priestley, seconded by Councilmember El-Alamin, that this matter be sent to COUNCIL. No Votes were taken.*

**A motion was made by Councilmember Lewis, seconded by*

Councilmember Pfeiffer, that this matter stay in SPECIAL AFFAIRS COMMITTEE (2-24-2025). This motion PASSED by the following vote:

Aye: 8 – Councilmember Burns, Councilmember Mushatt, Councilmember Pfeiffer, Councilmember Jarrett, Councilmember El-Alamin, Councilmember Lewis, Councilmember Priestley, and Councilmember Winfrey-Carter

No: 0 –

250041-T Appointment/Board of Review/Shirley Wilson Johnson/9th Ward

Resolution resolving that the Flint City Council approves the appointment of Shirley Wilson Johnson (2715 Lakewood Drive, Flint, Michigan, 48507) as 9th Ward representative, for a three-year term commencing upon adoption of this resolution and expiring December 31, 2028.

**A motion was made by Councilmember Pfeiffer, seconded by Councilmember Priestley, that this matter be sent to COUNCIL. This motion PASSED by the following vote:*

Aye: 8 – Councilmember Mushatt, Councilmember Pfeiffer, Councilmember Jarrett, Councilmember El-Alamin, Councilmember Lewis, Councilmember Priestley, Councilmember Winfrey-Carter, and Councilmember Burns

No: 0 –

ADJOURNMENT

Councilmember Priestley, seconded by Councilmember Pfeiffer, made a motion to Adjourn. This Special Affairs Committee Meeting Adjourned at 6:01 p.m.

This Motion PASSED by a VOTE of 8:0.

Respectfully transcribed and submitted,

*Jasmine Green
City Council Secretary*



250070-T

City of Flint, Michigan

Third Floor, City Hall
1101 S. Saginaw Street
Flint, Michigan 48502
www.cityofflint.com

Meeting Minutes -FINAL

Monday, February 10, 2025

6:18 PM

City Council Chambers

CITY COUNCIL

Ladel Lewis, President, Ward 2
Candice Mushatt, Vice President, Ward 7

Leon El-Alamin, Ward 1
Judy Priestley, Ward 4
Tonya Burns, Ward 6

VACANT, Ward 3
Jerri Winfrey-Carter, Ward 5
Dennis Pfeiffer, Ward 8

Jonathan Jarrett, Ward 9

Davina Donahue, City Clerk

CALL TO ORDER

City Clerk Davina Donahue called this City Council meeting back to order at 6:18 pm. for the purpose of electing a City Council President, in accordance with Section 3-201(B) of the Flint City Charter.

ROLL CALL

Present: Councilmembers El-Alamin, Lewis, Priestley, Winfrey-Carter, Burns, Mushatt, Pfeiffer, and Jarrett

COUNCIL MOTION

Councilmember Priestley, seconded by Councilmember Mushatt, made a motion to move the Organization of the City Council (Council President, Vice President, and Other Officers and Committees) vote to the end of Agenda. This motion PASSED by the following vote:

Aye: 7 – Councilmember El-Alamin, Councilmember Lewis, Councilmember Priestley, Councilmember Winfrey-Carter, Councilmember Burns, Councilmember Mushatt, and Councilmember Jarrett

No: 1 – Councilmember Pfeiffer

CONSIDERATION OF APPLICANTS (CANDIDATES) – 3RD WARD COUNCILMEMBER

Consideration of Applicants/Candidates Regarding the Vacancy in the Office of 3rd Ward Council Member, per Flint City Charter Section 2-410(B).

CURRENT APPLICANTS/CANDIDATES:

- 1. Beverly L. Biggs-Leavy*
- 2. AC Dumas*
- 3. Richard F. Jones*
- 4. Kerry L. Nelson*

The rounds proceeded as follows:

ROUND #152

- El-Alamin @ Nelson
- Lewis @ Nelson
- Priestley @ Nelson
- Winfrey-Carter @ Biggs-Leavy
- Burns @ ABSTAIN
- Mushatt @ Nelson
- Pfeiffer @ Dumas
- Jarrett @ Biggs-Leavy

ROUND #153

- El-Alamin @ Nelson

- Lewis @ Nelson
- Priestley @ Nelson
- Winfrey-Carter @ Biggs-Leavy
- Burns @ ABSTAIN
- Mushatt @ Nelson
- Pfeiffer @ Dumas
- Jarrett @ Biggs-Leavy

ROUND #154

- El-Alamin @ Nelson
- Lewis @ Nelson
- Priestley @ Nelson
- Winfrey-Carter @ Biggs-Leavy
- Burns @ NOT IN
- Mushatt @ Nelson
- Pfeiffer @ Dumas
- Jarrett @ Biggs-Leavy

ROUND #155

- El-Alamin @ Nelson
- Lewis @ Nelson
- Priestley @ Nelson
- Winfrey-Carter @ Biggs-Leavy
- Burns @ NOT IN
- Mushatt @ Nelson
- Pfeiffer @ Dumas
- Jarrett @ Biggs-Leavy

ROUND #156

- El-Alamin @ Nelson

Lewis @ Nelson

X Priestley @ Nelson

Winfrey-Carter @ Biggs-Leavy

Burns @ NOT IN

Mushatt @ Nelson

Pfeiffer @ Dumas

Jarrett @ Biggs-Leavy

ROUND #157

El-Alamin @ Nelson

Lewis @ Nelson

Priestley @ Nelson

X Winfrey-Carter @ Biggs-Leavy

Burns @ ABSENT

Mushatt @ Nelson

Pfeiffer @ Dumas

Jarrett @ Biggs-Leavy

ROUND #158

El-Alamin @ Nelson

Lewis @ Nelson

Priestley @ Nelson

Winfrey-Carter @ Biggs-Leavy

X Burns @ ABSENT

Mushatt @ Nelson

Pfeiffer @ Dumas

Jarrett @ Biggs-Leavy

ROUND #159

El-Alamin @ Nelson

Lewis @ Nelson

- Priestley @ Nelson
- Winfrey-Carter @ Biggs-Leavy
- Burns @ ABSENT
- X Mushatt @ Nelson
- Pfeiffer @ Dumas
- Jarrett @ Biggs-Leavy

ROUND #160

- El-Alamin @ Nelson
- Lewis @ Nelson
- Priestley @ Nelson
- Winfrey-Carter @ Biggs-Leavy
- Burns @ ABSENT
- Mushatt @ Nelson
- X Pfeiffer @ Dumas
- Jarrett @ Biggs-Leavy

ROUND #161

- El-Alamin @ Nelson
- Lewis @ Nelson
- Priestley @ Nelson
- Winfrey-Carter @ Biggs-Leavy
- Burns @ ABSENT
- Mushatt @ Nelson
- Pfeiffer @ Dumas
- X Jarrett @ Biggs-Leavy

ROUND #162

- X El-Alamin @ Nelson
- Lewis @ Nelson
- Priestley @ Nelson

- Winfrey-Carter @ Biggs-Leavy
- Burns @ ABSENT
- Mushatt @ Nelson
- Pfeiffer @ Dumas
- Jarrett @ Biggs-Leavy

ROUND #163

- El-Alamin @ Nelson
- X Lewis @ Nelson
- Priestley @ NOT IN
- Winfrey-Carter @ Biggs-Leavy
- Burns @ ABSENT
- Mushatt @ Nelson
- Pfeiffer @ Dumas
- Jarrett @ Biggs-Leavy

ROUND #164

- El-Alamin @ Nelson
- Lewis @ Nelson
- X Priestley @ NOT IN
- Winfrey-Carter @ Biggs-Leavy
- Burns @ ABSENT
- Mushatt @ Nelson
- Pfeiffer @ Dumas
- Jarrett @ Biggs-Leavy

ROUND #165

- El-Alamin @ Nelson
- Lewis @ Nelson
- Priestley @ NOT IN
- X Winfrey-Carter @ Biggs-Leavy

- Burns @ ABSENT
- Mushatt @ Nelson
- Pfeiffer @ Dumas
- Jarrett @ Biggs-Leavy

ROUND #166

- El-Alamin @ Nelson
- Lewis @ Nelson
- Priestley @ ABSENT
- Winfrey-Carter @ Biggs-Leavy

Burns @ ABSENT

X Mushatt @ Nelson

- Pfeiffer @ Dumas
- Jarrett @ Biggs-Leavy

ROUND #167

- El-Alamin @ Nelson
- Lewis @ Nelson
- Priestley @ Nelson
- Winfrey-Carter @ Biggs-Leavy

Burns @ ABSENT

Mushatt @ Nelson

X Pfeiffer @ Dumas

Jarrett @ Biggs-Leavy

ROUND #168

- El-Alamin @ Nelson
- Lewis @ Nelson
- Priestley @ Nelson
- Winfrey-Carter @ Biggs-Leavy

- Burns @ ABSENT
- Mushatt @ Nelson
- Pfeiffer @ Dumas
- Jarrett @ Biggs-Leavy

COUNCIL MOTION

Councilmember Pfeiffer, seconded by Councilmember Priestley, made a motion to Table the 3rd Ward Appointment to the next City Council Meeting (2-24-2025). This motion PASSED by the following vote:

Aye: 7 – Councilmember Lewis, Councilmember Priestley, Councilmember Winfrey-Carter, Councilmember Mushatt, Councilmember Pfeiffer, Councilmember Jarrett, and Councilmember El-Alamin

No: 0 –

Absent: Councilmember Burns

PLEDGE OF ALLEGIANCE

Led by Councilmember Pfeiffer

PRAYER OR BLESSING

Prayer led by Harold Woodson a member of Bethel United Methodist Church

READING OF DISORDERLY PERSON CITY CODE SUBSECTION

Read Into Record

REQUEST FOR AGENDA CHANGES/ADDITIONS

NONE

PUBLIC HEARING

240341.6 Public Hearing/Roberts Street Vacation

A Public Hearing to consider the vacation of Roberts Street, between E. Stewart Avenue and the North Lot Lines of Lot 234 (4401 Roberts St) and Lot 285 (4402 Roberts St) of the Maplewood Plat, for the purpose of receiving comments from all interested parties.

HELD

RESOLUTIONS

240341.1 Recommending Vacation of Roberts Street/between East Stewart Avenue/North Lot Lines of Lot 234 (4401 Roberts St.) and Lot 285 (4402 Roberts St.) of the Maplewood Plat

Resolution resolving that Robert Street between E. Stewart Ave and the North lot lines of Lot 234 (4401 Roberts St) and Lot 285 (4402 Roberts St) of the Maplewood Plat is hereby vacated and discontinued forever as a public street, alley, or public ground; public utilities will remain in place. AND, further resolving that the City Clerk shall, within (30) days of this action, record a certified copy of said resolution to the State Treasurer.

**A motion was made by Councilmember Pfeiffer, seconded by Councilmember Priestley, that this matter be ADOPTED. This motion PASSED by the following vote:*

Aye: 8 – Councilmember Priestley, Councilmember Winfrey-Carter, Councilmember Burns, Councilmember Mushatt, Councilmember Pfeiffer, Councilmember Jarrett, Councilmember El-Alamin, and Councilmember Lewis

No: 0 –

PUBLIC COMMENT

10 Public Speakers

COUNCIL RESPONSE

Councilmembers to respond (Burns, Winfrey-Carter, El-Alamin, and Lewis)

CONSENT AGENDA

PRESENTATION OF MINUTES

250029-T DRAFT/PROPOSED Summary Minutes/ Special City Council Meeting /January 22, 2025

DRAFT/PROPOSED Summary Minutes of the Special City Council Meeting held Wednesday, January 22, 2025, at 5:06 p.m., in the Council Chambers, 3rd Floor, City Hall.

This Matter PASSED on the Consent Agenda

250030-T DRAFT/PROPOSED Summary Minutes/Flint City Council/Finance Committee Meeting/January 22, 2025

DRAFT/PROPOSED Summary Minutes of the Flint City Finance Committee Meeting held Wednesday, January 22, 2025, at 6:21 p.m., in the Council Chambers, 3rd Floor, City Hall.

This Matter PASSED on the Consent Agenda

250031-T DRAFT/PROPOSED Summary Minutes/Flint City Council/Legislative Committee Meeting/January 22, 2025

DRAFT/PROPOSED Summary Minutes of the Flint City Legislative Committee Meeting held Wednesday, January 22, 2025, at 6:48 p.m., in the Council Chambers, 3rd Floor, City Hall.

This Matter PASSED on the Consent Agenda

250032-T DRAFT/PROPOSED Summary Minutes/Flint City Council/Governmental Operations Committee Meeting/January 22, 2025,

DRAFT/PROPOSED Summary Minutes of the Flint City Governmental Operations Committee Meeting held Wednesday, January 22, 2025, at 7:02 p.m., in the Council Chambers, 3rd Floor, City Hall.

This Matter PASSED on the Consent Agenda

250044-T DRAFT/PROPOSED Summary Minutes/Flint City Council/Special Affairs Committee Meeting/January 27, 2025

DRAFT/PROPOSED Summary Minutes of the Flint City Special Affairs Committee Meeting held Wednesday, January 27, 2025, at 4:45 p.m., in the Council Chambers, 3rd Floor, City Hall.

This Matter PASSED on the Consent Agenda

250045-T DRAFT/PROPOSED Summary Minutes/Flint City Council/Regular Meeting/January 27, 2025

DRAFT/PROPOSED Summary Minutes of the Flint City Regular Meeting held Wednesday, January 27, 2025, at 5:52 p.m., in the Council Chambers, 3rd Floor, City Hall.

This Matter PASSED on the Consent Agenda

APPOINTMENTS

250038-T Appointment/Flint Planning Commission/Edquan Dantzler/1st Ward

Resolution resolving that the Flint City Council approves the appointment of Edquan N. Dantzler, of 6702 Sally Court, Flint MI 48505, to the 1st Ward seat on the Planning Commission, to serve a term from April 1, 2025 to March 31, 2028.

This Matter PASSED on the Consent Agenda

APPOINTMENTS (May Be Referred from Special Affairs)

250037.1-T Appointment/Community-Wide Advisory Council/Joyce Ellis McNeal/8th Ward

Resolution resolving that the Flint City Council approves the appointment of Joyce Ellis-McNeal, (4021 Greenbrook Lane, Flint Michigan 48507), to fill the 8th Ward seat on the City-Wide Advisory Council (CWAC), as requested by the 8th Ward Flint City Councilmember Dennis Pfeiffer, for a term of March 1, 2025, to February 28, 2028.

SEPARATED FROM THE MASTER RESOLUTION

250041-T Appointment/Board of Review/Shirley Wilson Johnson/9th Ward

Resolution resolving that the Flint City Council approves the appointment of Shirley Wilson Johnson (2715 Lakewood Drive, Flint, Michigan, 48507) as 9th Ward representative, for a three-year term commencing upon adoption of this resolution and expiring December 31, 2028.

This Matter PASSED on the Consent Agenda

RESOLUTIONS (Continued)

250033-T Grant Acceptance/ Energy Efficiency and Conservation Block Grant/Purchase EV Charging Stations

Resolution resolving that the appropriate City officials are authorized to do all things necessary to accept the grant funds and amend the FY25 budget set forth in the grant from the United States Department of Energy in the amount of up to \$144,050.00 to appropriate revenue and expenditure amounts and to make the grant funds available from January 1st, 2025 through December 31st, 2025. AND further resolved that the division of purchases and supplies is hereby authorized to issue a purchase order to for a total NOT-TO-EXCEED the amount of \$92,233.00 to Weinstein Electric Company.

SEPARATED FROM THE MASTER RESOLUTION

250034-T Budget Amendment/Second Quarter 2025

Resolution resolving that the appropriate officials are hereby authorized to do all things necessary to incorporate the approved appropriation changes into the FY 2025 operating budget of the City of Flint.

This Matter PASSED on the Consent Agenda

250035-T Contract/Genesee Health System/Flint RECAST Community Based Trainings

Resolution resolving that the appropriate City Officials are authorized to do all things necessary to enter into a contract with Genesee Health System in the amount NOT-TO-EXCEED \$153,755.00. [NOTE: Flint Re-Cast for Community Based Trainings]

This Matter PASSED on the Consent Agenda

250040-T Dearborn Life Insurance Company/Life and Short-Term Disability Insurance

Resolution resolving that the appropriate officials are hereby authorized to do all things necessary to enter into an agreement with Dearborn National Life Insurance Company to continue providing the City with its short-term disability and life insurance coverage for the remainder of FY2025 for the amount of \$70,000.00, and \$140,000 for the period July 1, 2025-March 1, 2026, pending adoption of the FYE2026 budget, for a total amount NOT-TO-EXCEED \$210,000.00.

This Matter PASSED on the Consent Agenda

250043-T Grant Acceptance/The Department of Housing and Urban Development (HUD) Lead-Based Paint Hazard Control/Amend to 2024-25 Budget

Resolution resolving that the appropriate City officials are authorized to do all things necessary to, accept the Lead-Based Paint and Hazard Control grant, amend the 204-25 budget, appropriate grant funding for revenue and expenditures in future fiscal years as long as funds are available from the funder, and abide by the terms and conditions of the grant from The Department of Housing and Urban Development, in the amount NOT-TO-EXCEED \$3,059,006.68 over the 48-month grant period, from November 15, 2024-November 15, 2028.

This Matter PASSED on the Consent Agenda

RESOLUTION (May Be Referred from Special Affairs)

250042-T Reallocation of ARPA Funds/Bethel United Methodist church's Food Pantry/Food access and Food Support System

Resolution resolving that the appropriate City Officials are hereby authorized to do all things necessary, including executing any necessary agreements, to appropriate \$50,000.00 in funding to Bethel United Methodist Church for their Food Pantry program. Before the funds are spent, the City of Flint's ARPA administration, compliance, and implementation firm shall review and ensure compliance with the latest US Department of Treasury final rules.

This Matter PASSED on the Consent Agenda

INTRODUCTION AND FIRST READING OF ORDINANCES

240426.2-T Second Amendment/Amended Ordinance/Code
Amendment/Ordinance/Chapter 24 (Housing)/Article IV (Fair Chance Access to Rental Housing)/Sections 24-114 to 24-127

An amended ordinance to amend the Flint City Code of Ordinances by amending Chapter 24, Housing, by the addition of Article IV, Fair Chance Access to Rental Housing, Sections 24-114 to 24-127. [NOTE: This ordinance to become effective 30 days after adoption.]. [NOTE: ordinance amended to add specific information under Section 24-119(B)(2) with regard to criminal sexual conduct.] [NOTE: Second Amendment to Ordinance amended to change some adverse action or conviction dates from 10 to 5 years to 3 years.]

This Matter PASSED on the Consent Agenda

INTRODUCTION AND FIRST READING OF ORDINANCES (May Be Referred from Special Affairs)

240430.1-T Amended Ordinance/Code Amendment/Ordinance/Chapter25 (Community Development)/Article I (Community Benefits Agreements)/Sections 25-1 to 25-7

An amended ordinance to amend the Flint City Code of Ordinances by amending Chapter 25, Community Development, by the addition of Article I, Community Benefits Agreements. [NOTE: This Ordinance to become effective 30 days after adoption.]. [NOTE: Ordinance amended to add Developer definition information, Tier Project estimations and public hearing details, agreement specifications, and community engagement processes.]

This Matter PASSED on the Consent Agenda

CONSENT AGENDA VOTE

Councilmember Priestley, seconded by Councilmember El-Alamin, made a motion to Approve the Consent Agenda with any separations (All Meeting Minutes (Placed on File with any Corrections), Appts. 250038-T, 250041-T, Resos. 250034-T, 250035-T, 250040-T, 250043-T, 250042-T, Ord. 240426.2-T, and Ord. 240430.1-T is a part of the Consent Agenda). This Motion PASSED by the following vote:

Aye: 8 – Councilmember Winfrey-Carter, Councilmember Burns, Councilmember Mushatt, Councilmember Pfeiffer, Councilmember Jarrett, Councilmember El-Alamin, Councilmember Lewis, and Councilmember Priestley

No: 0 –

SEPARATED FROM MASTER RESOLUTION (CONSENT AGENDA)

250037.1-T Appointment/Community-Wide Advisory Council/Joyce Ellis McNeal/8th Ward

Resolution resolving that the Flint City Council approves the appointment of Joyce Ellis-McNeal, (4021 Greenbrook Lane, Flint Michigan 48507), to fill the 8th Ward seat on the City-Wide Advisory Council (CWAC), as requested by the 8th Ward Flint City Councilmember Dennis Pfeiffer, for a term of March 1, 2025, to February 28, 2028.

**A motion was made by Councilmember Priestley, seconded by Councilmember El-Alamin, that this matter be APPROVED. No Votes were Taken.*

**A motion was made by Councilmember Lewis, seconded by Councilmember*

Mushatt, that this matter stay in SPECIAL AFFAIRS COMMITTEE. This motion FAILED by the following vote:

Aye: 4 – Councilmember Mushatt, Councilmember El-Alamin, Councilmember Lewis, and Councilmember Priestley

No: 4 – Councilmember Burns, Councilmember Pfeiffer, Councilmember Jarrett, and Councilmember Winfrey-Carter

**A motion was made by Councilmember Priestley, seconded by Councilmember El-Alamin, that this matter be APPROVED. This motion PASSED by the following vote:*

Aye: 7 – Councilmember Mushatt, Councilmember Pfeiffer, Councilmember Jarrett, Councilmember El-Alamin, Councilmember Priestley, Councilmember Winfrey-Carter, and Councilmember Burns

No: 1 – Councilmember Lewis

250033-T Grant Acceptance/ Energy Efficiency and Conservation Block Grant/Purchase EV Charging Stations

Resolution resolving that the appropriate City officials are authorized to do all things necessary to accept the grant funds and amend the FY25 budget set forth in the grant from the United States Department of Energy in the amount of up to \$144,050.00 to appropriate revenue and expenditure amounts and to make the grant funds available from January 1st, 2025 through December 31st, 2025. AND further resolved that the division of purchases and supplies is hereby authorized to issue a purchase order to for a total NOT-TO-EXCEED the amount of \$92,233.00 to Weinstein Electric Company.

**A motion was made by Councilmember Pfeiffer, seconded by Councilmember El-Alamin, that this matter be APPROVED. This motion PASSED by the following vote:*

Aye: 6 – Councilmember Pfeiffer, Councilmember Jarrett, Councilmember El-Alamin, Councilmember Lewis, Councilmember Burns, and Councilmember Mushatt

No: 1 – Councilmember Priestley

Absent: Councilmember Winfrey-Carter

ORGANIZATION OF THE CITY COUNCIL (Council President)

The City Council shall elect from its members a presiding officer who shall be known as the President of the Council.

Clerk Donahue stated as explained in previous Rounds that Councilmembers' names would be called in voting order, and that each member should then state the name of the individual that they want to elect as Council President. The rounds proceeded as follows:

ROUND #711

- El-Alamin @ Mushatt
- Lewis @ Mushatt
- Priestley @ Mushatt
- Winfrey-Carter @ Winfrey-Carter
- Burns @ Winfrey-Carter
- Mushatt @ Mushatt
- Pfeiffer @ Winfrey-Carter
- Jarrett @ NOT IN

FINAL COUNCIL COMMENTS

ADJOURNMENT

*Councilmember Winfrey-Carter, seconded by Councilmember Priestley, made a motion to Adjourn.
This City Council Meeting Adjourned at 8:08 p.m.*

This Motion PASSED by a VOTE of 8:0.

Respectfully transcribed and submitted,

*Jasmine Green
City Council Secretary*



250071-T

City of Flint, Michigan

Third Floor, City Hall
1101 S. Saginaw Street
Flint, Michigan 48502
www.cityofflint.com

Meeting Minutes – FINAL

Monday, February 17, 2025

5:09 PM

City Council Chambers

SPECIAL CITY COUNCIL

Ladel Lewis, President, Ward 2
Candice Mushatt, Vice President, Ward 7

Leon El-Alamin, Ward 1
Judy Priestley, Ward 4
Tonya Burns, Ward 6

VACANT, Ward 3
Jerri Winfrey-Carter, Ward 5
Dennis Pfeiffer, Ward 8

Jonathan Jarrett, Ward 9

Davina Donahue, City Clerk

This Special City Council Meeting was called by 5th Ward Councilmember Jerri Winfrey-Carter and 6th Ward Councilmember Tonya Burns for the purpose of considering/discussing Reso No. 240511-T (Resolution Approving the Lease of Real Property Known as the Hasselbring Senior Center to Hasselbring Senior Center, a Senior Services Organization).

CALL TO ORDER

ROLL CALL

Present: Councilmembers Winfrey-Carter, Burns, Pfeiffer, and Jarrett

Absent: Councilmembers El-Alamin, Lewis, Priestley, and Mushatt

PLEDGE OF ALLEGIANCE

PRAYER OR BLESSING

READING OF DISORDERLY PERSON CITY CODE SUBSECTION

PUBLIC COMMENT

18 Public Speakers

COUNCIL RESPONSE

Councilmembers to Respond (Pfeiffer, Jarrett, Burns, and Winfrey-Carter)

ADJOURNMENT

This Special Meeting was Adjourned Due to a Lack of a Quorum, at approximately 6:48 p.m.

Respectfully transcribed and submitted,

Jasmine Green

City Council Secretary



250072-T

City of Flint, Michigan

Third Floor, City Hall
1101 S. Saginaw Street
Flint, Michigan 48502
www.cityofflint.com

Meeting Minutes – FINAL

Wednesday, February 19, 2025

5:08 PM

City Council Chambers

FINANCE COMMITTEE

Judy Priestley, Chairperson, Ward 4

Leon El-Alamin, Ward 1

VACANT, Ward 3

Tonya Burns, Ward 6

Dennis Pfeiffer, Ward 8

Ladel Lewis, Ward 2

Jerri Winfrey-Carter, Ward 5

Candice Mushatt, Ward 7

Jonathan Jarrett, Ward 9

Davina Donahue, City Clerk

ROLL CALL

Present: Councilmembers El-Alamin, Lewis, Priestley, Winfrey-Carter, Burns, Mushatt, Pfeiffer and Jarrett

(Councilmember Lewis arrived in her seat at approximately 5:39 p.m. during Council Discussion on Reso. 250050-T)

REQUEST FOR AGENDA CHANGES/ADDITIONS

NONE

PUBLIC COMMENT

COUNCIL RESPONSE

Councilmember to respond (Burns)

CONSENT AGENDA

RESOLUTIONS

250046-T CO #1/Weinstein Electric/Complete Electrical Work/Clara Hilborn Park

Resolution resolving that the appropriate City Officials are hereby authorized to do all things necessary including budget amendments to process a change order to increase contract 23-090 with Weinstein Electric by \$10,000 utilizing the OFAEC2021 accounts 296-737.310-963.000 and 296-737.310-801.000 for a revised total contract amount not to exceed \$90,657.85.

This Matter PASSED on the Consent Agenda

250047-T Support of Services Funding Incentive/Under the Workforce Innovation and Opportunity Act (WIOA) Through Genesee Shiawassee Thumb Michigan Works!

Resolution resolving that the appropriate City Officials are hereby authorized to do all things necessary to accept the funding incentive from GST Michigan Works provided under the WIOA to purchase turnout gear for six newly hired Firefighter Trainees and to appropriate the incentive funding award for revenue and expenditures for the FY25 budget year in the amount of \$15,000.00 and to record the funding and expenditures for the FY25 budget year in the amount of \$15,000.00 and to record the funding incentive award under REVENUE-REIMBURSEMENT account. AND further resolving that the Division of Purchases and Supplies is hereby authorized to issue Purchase Orders to Fire Department approved vendors for the purchase of turnout gear equipment, in an amount not-to-exceed \$15,000.00 for FY25 (07/01/24-06/30/25)

This Matter PASSED on the Consent Agenda

250048-T Crim Fitness Foundation/Flint RECAST/Community Based Mindfulness Trainings

Resolution resolving that the appropriate City Officials are authorized to do all things necessary to enter into a contract with CRIM Fitness Foundation in the amount not-to-exceed \$89,689.00.

This Matter PASSED on the Consent Agenda

250049-T Contract/Flint Police Department/Cloud-Based Management Software/SF Mobile-Vision Inc FY25

Resolution resolving that the proper City Officials, upon the City Council approval, are hereby authorized to enter into a five year agreement with SF Mobile-Vision in a first year amount of \$180,885.00 and annual amounts of \$160,605.00 and pending adoption of the FY26 (07/01/2025-06/30/2026), FY27 (07/01/2026-06/30/2027), FY28 (07/01/2027-06/30/2028) and FY29 (07/01/2028-06/30/2029) budgets for a combined five year total of \$823,305.00.

SEPARATED FROM THE MASTER RESOLUTION

250050-T Budget Amendment/Move Development Fund Balance/Building Additions and Improvements Account

Resolution resolving that the appropriate city officials, upon City Council's approval, are hereby authorized to process a budget amendment in the amount of \$560,000 from the Development fund balance to the Building Additions and Improvements account.

SEPARATED FROM THE MASTER RESOLUTION

250051-T CO#1/Lurvey Construction/South Building Renovation

Resolution resolving that the appropriate city officials, upon City Council's approval, are hereby authorized to do anything necessary including budget amendments to proceed with a \$617,198 change order to the existing contract with Lurvey Construction LLC in FY25 to complete renovations to the South Building of City Hall for a total contract amount of \$2,617,198.

SEPARATED FROM THE MASTER RESOLUTION

250052-T CO#1/Flint Housing Commission/Business and Community Services/Increase Abatement of The Atherton East Apartments

Resolution resolving that the appropriate City Officials are hereby to do all things necessary including budget amendments to process a change order to increase contract 19-035 with Flint Housing Commission by \$2,012,100 in the FHUD18CHOICE accounts 296-704.801-529.000 (revenue) and 296-704.801-963.000 (expense) for a revised total contract amount of \$2,568,091.03.

SEPARATED FROM THE MASTER RESOLUTION

CONSENT AGENDA VOTE

Councilmember Mushatt, seconded by Councilmember El-Alamin, made a motion to Approve the Consent Agenda with any separations (Reso. # 250046-T, 250047-T, and 250048-T are a part of the Consent Agenda [SENT TO COUNCIL 2-24-2025]). This Motion PASSED by the following vote:

Aye: 7 – Councilmember El-Alamin, Councilmember Priestley, Councilmember Winfrey-Carter, Councilmember Burns, Councilmember Mushatt, Councilmember Pfeiffer, and Councilmember Jarrett

No: 0 –

Absent: Councilmember Lewis

SEPARATED FROM MASTER RESOLUTION (CONSENT AGENDA)

250049-T Contract/Flint Police Department/Cloud-Based Management Software/SF Mobile-Vision Inc FY25

Resolution resolving that the proper City Officials, upon the City Council approval, are hereby authorized to enter into a five year agreement with SF Mobile-Vision in a first year amount of \$180,885.00 and annual amounts of \$160,605.00 and pending adoption of the FY26 (07/01/2025-06/30/2026), FY27 (07/01/2026-06/30/2027), FY28 (07/01/2027-06/30/2028) and FY29 (07/01/2028-06/30/2029) budgets for a combined five year total of \$823,305.00.

**A motion was made by Councilmember Pfeiffer, seconded by Councilmember El-Alamin, that this matter be sent to COUNCIL (2-24-2025). This motion PASSED by the following vote:*

Aye: 7 – Councilmember El-Alamin, Councilmember Priestley, Councilmember Winfrey-Carter, Councilmember Burns, Councilmember Mushatt, Councilmember Pfeiffer, and Councilmember Jarrett

No: 0 –

Absent: Councilmember Lewis

250050-T Budget Amendment/Move Development Fund Balance/Building Additions and Improvements Account

Resolution resolving that the appropriate city officials, upon City Council's approval, are hereby authorized to process a budget amendment in the amount of \$560,000 from the Development fund balance to the Building Additions and Improvements account.

**A motion was made by Councilmember Mushatt, seconded by Councilmember El-Alamin, that this matter be sent to COUNCIL (2-24-2025). This motion PASSED by the following vote:*

Aye: 8 – Councilmember Priestley, Councilmember Winfrey-Carter, Councilmember Burns, Councilmember Mushatt, Councilmember Pfeiffer, Councilmember Jarrett, Councilmember El-Alamin, and Councilmember Lewis

No: 0 –

250051-T CO#1/Lurvey Construction/South Building Renovation

Resolution resolving that the appropriate city officials, upon City Council's approval, are hereby authorized to do anything necessary including budget amendments to proceed with a \$617,198 change order to the existing contract with Lurvey Construction LLC in FY25 to complete renovations to the South Building of City Hall for a total contract amount of \$2,617,198.

**A motion was made by Councilmember El-Alamin, seconded by Councilmember Mushatt, that this matter be sent to COUNCIL (2-24-2025). This motion PASSED by the following vote:*

Aye: 8 – Councilmember Winfrey-Carter, Councilmember Burns, Councilmember Mushatt, Councilmember Pfeiffer, Councilmember Jarrett, Councilmember El-Alamin, Councilmember Lewis, and Councilmember Priestley

No: 0 –

250052-T CO#1/Flint Housing Commission/Business and Community Services/Increase Abatement of The Atherton East Apartments

Resolution resolving that the appropriate City Officials are hereby to do all things necessary including budget amendments to process a change order to increase contract 19-035 with Flint Housing Commission by \$2,012,100 in the FHUD18CHOICE accounts 296-704.801-529.000 (revenue) and 296-704.801-963.000 (expense) for a revised total contract amount of \$2,568,091.03.

**A motion was made by Councilmember Mushatt, seconded by Councilmember Lewis, that this matter be sent to COUNCIL (2-24-2025). This motion PASSED by the following vote:*

Aye: 8 – Councilmember Burns, Councilmember Mushatt, Councilmember Pfeiffer, Councilmember Jarrett, Councilmember El-Alamin, Councilmember Lewis, and Councilmember Priestley, and Councilmember Winfrey-Carter

No: 0 –

ADJOURNMENT

Councilmember Mushatt, seconded by Councilmember El-Alamin, made a motion to Adjourn. This Finance Committee Meeting Adjourned at 5:56 p.m.

This Motion PASSED by a VOTE of 8:0

Respectfully transcribed and submitted,

*Jasmine Green
City Council Secretary*



250073-T

City of Flint, Michigan

Third Floor, City Hall
1101 S. Saginaw Street
Flint, Michigan 48502
www.cityofflint.com

Meeting Minutes – FINAL

Wednesday, February 19, 2025

6:05 PM

City Council Chambers

GOVERNMENTAL OPERATIONS COMMITTEE

VACANT, Chairperson

Leon El-Alamin, Ward 1

VACANT, Ward 3

Jerri Winfrey-Carter, Ward 5

Candice Mushatt, Ward 7

Jonathan Jarrett, Ward 9

Ladel Lewis, Ward 2

Judy Priestley, Ward 4

Tonya Burns, Ward 6

Dennis Pfeiffer, Ward 8

Davina Donahue, City Clerk

ROLL CALL

Present: Councilmembers El-Alamin, Lewis, Priestley, Winfrey-Carter, Burns, Mushatt, Pfeiffer and Jarrett

REQUEST FOR AGENDA CHANGES/ADDITIONS

Vice President Mushatt ordered without objection to accept Add-on #1 – Appointment for Patricia Leadmon to The Board of Review.

PUBLIC COMMENT

COUNCIL RESPONSE

Councilmembers to Respond (Lewis, and Mushatt)

CONSENT AGENDA

APPOINTMENTS

250053-T Appointment/Board of Review/Karen E. Spencer-Kea/6th Ward

Resolution resolving that the Flint City Council approves the appointment of Karen E. Spencer-Kea (1012 Fremont Street, Flint, Michigan, 48504) to the Board of Review, as 6th Ward representative, for a _____ term commencing upon adoption of this resolution and expiring _____.

This Matter PASSED on the Consent Agenda

250054-T Appointment/Flint Planning Commission/Willie Buford/2nd Ward

Resolution resolving that the Flint City Council approves the appointment of Willie Buford (3206 Keyes St., Flint, Michigan, 48504) to fill the 2nd Ward seat on the Planning Commission, as requested by 2nd Ward Flint City Councilmember Ladel Lewis, for a term of _____, to _____.

SEPARATED FROM THE MASTER RESOLUTION

250055-T Appointment/Community-Wide Advisory Council/Joshua J. Moore/4th Ward

Resolution resolving that the Flint City Council approves the appointment of Joshua J. Moore (1726 Illinois Avenue, Flint Michigan 48506), to fill the 4th Ward seat on the City-Wide Advisory Council (CWAC), as requested by the 4th Ward Flint City Councilmember Judy Priestley, for a term of _____, to _____.

This Matter PASSED on the Consent Agenda

ADD-ON #1 Appointment/Board of Review/Patricia Leadmon/4th Ward

Resolution resolving that the Flint City Council approves the appointment of Patricia Leadmon (2417 Burns Street, Flint, Michigan, 48506) as 4th Ward representative to the Board of Review, for a three year term commencing immediately upon adoption of this resolution and expiring January 1, 2028.

This Matter PASSED on the Consent Agenda

ROLL CALL

Present: Councilmembers El-Alamin, Lewis, Priestley, Winfrey-Carter, Burns, Mushatt, and Jarrett

Absent: Councilmember Pfeiffer

(Councilmember Pfeiffer left this Governmental Operations Committee meeting at approximately 6:13 p.m. during Public Comment)

CONSENT AGENDA VOTE

Councilmember Priestley, seconded by Councilmember El-Alamin, made a motion to Approve the Consent Agenda with any separations (Reso. # 250053-T, 250055-T, and Add-On #1 are a part of the Consent Agenda [SENT TO COUNCIL 2-24-2025]). This Motion PASSED by the following vote:

Aye: 7 – Councilmember El-Alamin, Councilmember Lewis, Councilmember Priestley, Councilmember Winfrey-Carter, Councilmember Burns, Councilmember Mushatt, and Councilmember Jarrett

No: 0 –

Absent: Councilmember Pfeiffer

SEPARATED FROM MASTER RESOLUTION (CONSENT AGENDA)

250054-T Appointment/Flint Planning Commission/Willie Buford/2nd Ward

Resolution resolving that the Flint City Council approves the appointment of Willie Buford (3206 Keyes St., Flint, Michigan, 48504) to fill the 2nd Ward seat on the Planning Commission, as requested by 2nd Ward Flint City Councilmember Ladel Lewis, for a term of _____, to _____.

**A motion was made by Councilmember Priestley, seconded by Councilmember El-Alamin, that this matter be sent to COUNCIL (2-24-2025). No Votes were Taken*

**A motion was made by Councilmember Priestley, seconded by Councilmember Lewis, that this matter be POSTPONED INDEFINITELY. This motion PASSED by the following vote:*

Aye: 7 – Councilmember Lewis, Councilmember Priestley, Councilmember Winfrey-Carter, Councilmember Burns, Councilmember Mushatt, Councilmember

Jarrett, and Councilmember El-Alamin

No: 0 –

Absent: Councilmember Pfeiffer

ADJOURNMENT

Councilmember Priestley, seconded by Councilmember El-Alamin, made a motion to Adjourn. This Governmental Operations Committee Meeting Adjourned at 6:29 p.m.

This Motion PASSED by a VOTE of 7:0

Absent: (Pfeiffer)

Respectfully transcribed and submitted,

*Jasmine Green
City Council Secretary*



250074-T

City of Flint, Michigan

Third Floor, City Hall
1101 S. Saginaw Street
Flint, Michigan 48502
www.cityofflint.com

Meeting Minutes – FINAL

Wednesday February 19, 2025

City Council Chambers

LEGISLATIVE COMMITTEE

VACANT, Chairperson

Leon El-Alamin, Ward 1	Ladel Lewis, Ward 2
VACANT, Ward 3	Judy Priestley, Ward 4
Jerri Winfrey-Carter, Ward 5	Tonya Burns, Ward 6
Candice Mushatt, Ward 7	Dennis Pfeiffer, Ward 8
Jonathan Jarrett, Ward 9	
Davina Donahue, City Clerk	

CANCELLED MEETING

ROLL CALL

REQUEST FOR AGENDA CHANGES/ADDITIONS

PUBLIC COMMENT

COUNCIL RESPONSE

CONSENT AGENDA

ORDINANCES

ADJOURNMENT



250075-T

City of Flint, Michigan

Third Floor, City Hall
1101 S. Saginaw Street
Flint, Michigan 48502
www.cityofflint.com

MEETING MINUTES – FINAL

Monday, February 24, 2025

4:44 PM

City Council Chambers

SPECIAL AFFAIRS COMMITTEE

Candice Mushatt, Vice President, Ward 7

Leon El-Alamin, Ward 1	Ladel Lewis, Ward 2
VACANT, Ward 3	Judy Priestley, Ward 4
Jerri Winfrey-Carter, Ward 5	Tonya Burns, Ward 6
Dennis Pfeiffer, Ward 8	Jonathan Jarrett, Ward 9

Davina Donahue, City Clerk

ROLL CALL

Present: Councilmembers El-Alamin, Lewis, Priestley, Winfrey-Carter, Burns, Mushatt, and Jarrett

Absent: Councilmember Pfeiffer

READING OF DISORDERLY PERSON CITY CODE SUBSECTION

Read Into Record

REQUEST FOR AGENDA CHANGES/ADDITIONS

None

PUBLIC COMMENT

1 Public Speaker

COUNCIL RESPONSE

Councilmembers to respond (Lewis)

CONSENT AGENDA

RESOLUTIONS

APPOINTMENTS

2500039-T Appointment/Rodrick L. Green/3rd Ward/Flint Planning Commission

Resolution resolving that the Flint City Council approves the appointment of Rodrick L. Green, of 1183 E. Holbrook Ave., Flint, MI 48505, to the 3rd Ward seat on the Planning Commission, to serve a term from March 1, 2025 to February 28, 2028.

SEPARATED FROM THE MASTER RESOLUTION

250057-T Reappointment/City-Wide Advisory Council/Peggy Stribling/2nd Ward

Resolution resolving that the Flint City Council approves the reappointment of Peggy Stribling (1714 W. Dartmouth Street, Flint, Michigan, 48504) as a 2nd Ward representative on the City-Wide Advisory Council (CWAC), as requested by 2nd Ward Flint City Councilmember Ladel Lewis, for a term of March 1, 2025, to February 28, 2028.

SEPARATED FROM THE MASTER RESOLUTION

ORDINANCES

CONSENT AGENDA VOTE

Councilmember Priestley, seconded by Councilmember El-Alamin, made a motion to Approve the Consent

Agenda with any separations (SEND TO COUNCIL). Councilmember Lewis asked for total SEPARATION.

SEPARATED FROM MASTER RESOLUTION (CONSENT AGENDA)

250039-T Appointment/Flint Planning Commission/Rodrick L. Green/3rd Ward

Resolution resolving that the Flint City Council approves the appointment of Rodrick L. Green, of 1183 E. Holbrook Ave., Flint, MI 48505, to the 3rd Ward seat on the Planning Commission, to serve a term from March 1, 2025 to February 28, 2028.

**A motion was made by Councilmember Lewis, seconded by Councilmember El-Alamin, that this matter be sent to COUNCIL. This motion PASSED by the following vote:*

Aye: 7 – Councilmember Burns, Councilmember Mushatt, Councilmember Jarrett, Councilmember El-Alamin, Councilmember Lewis, Councilmember Priestley, and Councilmember Winfrey-Carter

No: 0 –

Absent: Councilmember Pfeiffer

250057-T Reappointment/City-Wide Advisory Council/Peggy Stribling/2nd Ward

Resolution resolving that the Flint City Council approves the reappointment of Peggy Stribling (1714 W. Dartmouth Street, Flint, Michigan, 48504) as a 2nd Ward representative on the City-Wide Advisory Council (CWAC), as requested by 2nd Ward Flint City Councilmember Ladel Lewis, for a term of March 1, 2025, to February 28, 2028.

**A motion was made by Councilmember Lewis, seconded by Councilmember El-Alamin, that this matter be sent to COUNCIL. This motion PASSED by the following vote:*

Aye: 7 – Councilmember Burns, Councilmember Mushatt, Councilmember Jarrett, Councilmember El-Alamin, Councilmember Lewis, Councilmember Priestley, and Councilmember Winfrey-Carter

No: 0 –

Absent: Councilmember Pfeiffer

ADJOURNMENT

Councilmember Priestley, seconded by Councilmember El-Alamin, made a motion to Adjourn. This Special Affairs Committee Meeting Adjourned at 5:04 p.m.

This Motion PASSED by a VOTE of 7:0.

Absent: (Councilmember Pfeiffer)

Respectfully transcribed and submitted,

*Christel Snider
City Council Secretary*



250076-T

City of Flint, Michigan

Third Floor, City Hall
1101 S. Saginaw Street
Flint, Michigan 48502
www.cityofflint.com

Meeting Minutes -FINAL

Monday, February 24, 2025

5:30 PM

City Council Chambers

CITY COUNCIL

Ladel Lewis, President, Ward 2
Candice Mushatt, Vice President, Ward 7

Leon El-Alamin, Ward 1
Judy Priestley, Ward 4
Tonya Burns, Ward 6

VACANT, Ward 3
Jerri Winfrey-Carter, Ward 5
Dennis Pfeiffer, Ward 8

Jonathan Jarrett, Ward 9

Davina Donahue, City Clerk

CALL TO ORDER

City Clerk Davina Donahue called this City Council meeting back to order at 5:30 pm. for the purpose of electing a City Council President, in accordance with Section 3-201(B) of the Flint City Charter.

ROLL CALL

Present: Councilmembers El-Alamin, Lewis, Priestley, Winfrey-Carter, Burns, Mushatt, and Jarrett

Absent: Councilmember Pfeiffer

COUNCIL MOTION

Councilmember Priestley, seconded by Councilmember El-Alamin, made a motion to move the Organization of the City Council (Council President, Vice President, and Other Officers and Committees) vote to the end of Agenda after the 3rd Ward Appointment. This motion PASSED by the following vote:

Aye: 7 – Councilmember El-Alamin, Councilmember Lewis, Councilmember Priestley, Councilmember Winfrey-Carter, Councilmember Burns, Councilmember Mushatt, and Councilmember Jarrett

No: 0 –

Absent: Councilmember Pfeiffer

PLEDGE OF ALLEGIANCE

Led by Councilmember El-Alamin

PRAYER OR BLESSING

Prayer led by Councilmember Priestley

READING OF DISORDERLY PERSON CITY CODE SUBSECTION

Read Into Record

REQUEST FOR AGENDA CHANGES/ADDITIONS

NONE

PUBLIC COMMENT

2 Public Speakers

COUNCIL RESPONSE

Councilmembers to respond (Lewis)

RECONSIDERATION (Appointments)

240523-T Appointment/Tredale Kennedy/Flint Housing Commission

Resolution resolving that the Flint City Council approves the appointment of Tredale Kennedy to serve [the remainder of] a three-year term on the Board of the Flint Housing Commission, with such term commencing immediately and expiring on August 31, 2026. [NOTE: Tredale Kennedy will complete a [3]-year term replacing Leon El-Alamin, who resigned due to being elected to serve on the Flint City Council.]

**A motion was made by Councilmember El-Alamin, seconded by Councilmember Mushatt, that this matter be RECONSIDERED. This motion PASSED by the following vote:*

Aye: 7 – Councilmember El-Alamin, Councilmember Lewis, Councilmember Priestley, Councilmember Winfrey-Carter, Councilmember Burns, Councilmember Mushatt, and Councilmember Jarrett

No: 0 –

Absent: Councilmember Pfeiffer

RECONSIDERATION (Resolutions)

240548-T Reallocation of ARPA Funds/St. Mark Missionary Baptist Church/Community Outreach Center/Food Access and Food Support System

Resolution resolving that the appropriate City Officials are authorized to do all things necessary, including executing any necessary agreements, to appropriate \$50,000.00 in funding to St Mark Baptist Church's Community Outreach Center [to provide Food Access and Food System Support for the residents of Flint]. Before the funds are spent, the City of Flint's ARPA administration, compliance, and implementation firm shall review and ensure compliance with the latest US Department of Treasury final rules.

**A motion was made by Councilmember Burns, seconded by Councilmember*

Winfrey-Carter, that this matter be RECONSIDERED. This motion FAILED by the following vote:

Aye: 3 – Councilmember Winfrey-Carter, Councilmember Burns, and Councilmember Jarrett

No: 4 – Councilmember Lewis, Councilmember Priestley, Councilmember Mushatt, and Councilmember El-Alamin

Absent: Councilmember Pfeiffer

CONSENT AGENDA

APPOINTMENTS

250053-T Appointment/Board of Review/Karen E. Spencer-Kea/6th Ward

Resolution resolving that the Flint City Council approves the appointment of Karen E. Spencer-Kea (1012 Fremont Street, Flint, Michigan, 48504) to the Board of Review, as 6th Ward representative, for a _____ term commencing upon adoption of this resolution and expiring _____.

SEPARATED FROM THE MASTER RESOLUTION

250055-T Appointment/City-Wide Advisory Council/Joshua J. Moore/4th Ward

Resolution resolving that the Flint City Council approves the appointment of Joshua J. Moore (1726 Illinois Avenue, Flint Michigan 48506), to fill the 4th Ward seat on the City-Wide Advisory Council (CWAC), as requested by the 4th Ward Flint City Councilmember Judy Priestley, for a term of _____, to _____.

SEPARATED FROM THE MASTER RESOLUTION

250056-T Appointment/Board of Review/Patricia Leadmon/4th Ward

Resolution resolving that the Flint City Council approves the appointment of Patricia Leadmon (24017 Burns Street, Flint, Michigan, 48506) as 4th Ward representative to the Board of Review, for a three year term commencing immediately upon adoption of this resolution and expiring January 1, 2028.

This Matter PASSED on the Consent Agenda

APPOINTMENTS (May Be Referred from Special Affairs)

250039-T Appointment/Rodrick L. Green/3rd Ward/Flint Planning Commission

Resolution resolving that the Flint City Council approves the appointment of Rodrick L. Green, of 1183 E. Holbrook Ave., Flint, MI 48505, to the 3rd Ward seat on the Planning Commission, to serve a term from March 1, 2025, to February 28, 2028.

This Matter PASSED on the Consent Agenda

250057-T Reappointment/City-Wide Advisory Council/Peggy Stribling/2nd Ward

Resolution resolving that the Flint City Council approves the reappointment of Peggy Stribling (1714 W. Dartmouth Street, Flint, Michigan, 48504) as a 2nd Ward representative on the City-Wide Advisory Council (CWAC), as requested by 2nd Ward Flint City Councilmember Ladel Lewis, for a term of March 1, 2025, to February 28, 2028.

This Matter PASSED on the Consent Agenda

APPOINTMENTS (May be Reconsidered)

240523-T Appointment/Tredale Kennedy/Flint Housing Commission

Resolution resolving that the Flint City Council approves the appointment of Tredale Kennedy to serve [the remainder of] a three-year term on the Board of the Flint Housing Commission, with such term commencing immediately and expiring on August 31, 2026. [NOTE: Tredale Kennedy will complete a [3]-year term replacing Leon El-Alamin, who resigned due to being elected to serve on the Flint City Council.]

This Matter PASSED on the Consent Agenda

RESOLUTIONS

250046-T CO #1/Weinstein Electric/Complete Electrical Work/Clara Hilborn Park

Resolution resolving that the appropriate City Officials are hereby authorized to do all things necessary including budget amendments to process a change order to increase contract 23-090 with Weinstein Electric by \$10,000 utilizing the OFAEC2021 accounts 296-737.310-963.000 and 296-737.310-801.000 for a revised total contract amount not to exceed \$90,657.85.

This Matter PASSED on the Consent Agenda

- 250047-T Support of Services Funding Incentive/Under the Workforce Innovation and Opportunity Act (WIOA) Through Genesee Shiawassee Thumb Michigan Works!

Resolution resolving that the appropriate City Officials are hereby authorized to do all things necessary to accept the funding incentive from GST Michigan Works provided under the WIOA to purchase turnout gear for six newly hired Firefighter Trainees and to appropriate the incentive funding award for revenue and expenditures for the FY25 budget year in the amount of \$15,000.00 and to record the funding and expenditures for the FY25 budget year in the amount of \$15,000.00 and to record the funding incentive award under REVENUE-REIMBURSEMENT account. AND further resolving that the Division of Purchases and Supplies is hereby authorized to issue Purchase Orders to Fire Department approved vendors for the purchase of turnout gear equipment, in an amount not-to-exceed \$15,000.00 for FY25 (07/01/24-06/30/25)

This Matter PASSED on the Consent Agenda

- 250048-T Crim Fitness Foundation/Flint RECAST/Community Based Mindfulness Trainings

Resolution resolving that the appropriate City Officials are authorized to do all things necessary to enter into a contract with CRIM Fitness Foundation in the amount not-to-exceed \$89,689.00.

This Matter PASSED on the Consent Agenda

- 250049-T Contract/Flint Police Department/Cloud-Based Management Software/SF Mobile-Vision Inc FY25

Resolution resolving that the proper City Officials, upon the City Council approval, are hereby authorized to enter into a five year agreement with SF Mobile-Vision in a first year amount of \$180,885.00 and annual amounts of \$160,605.00 and pending

adoption of the FY26 (07/01/2025-06/30/2026), FY27 (07/01/2026-06/30/2027), FY28 (07/01/2027-06/30/2028) and FY29 (07/01/2028-06/30/2029) budgets for a combined five year total of \$823,305.00.

This Matter PASSED on the Consent Agenda

250050-T Budget Amendment/Move Development Fund Balance/Building Additions and Improvements Account

Resolution resolving that the appropriate city officials, upon City Council's approval, are hereby authorized to process a budget amendment in the amount of \$560,000 from the Development fund balance to the Building Additions and Improvements account.

This Matter PASSED on the Consent Agenda

250051-T CO#1/Lurvey Construction/South Building Renovation

Resolution resolving that the appropriate city officials, upon City Council's approval, are hereby authorized to do anything necessary including budget amendments to proceed with a \$617,198 change order to the existing contract with Lurvey Construction LLC in FY25 to complete renovations to the South Building of City Hall for a total contract amount of \$2,617,198.

This Matter PASSED on the Consent Agenda

250052-T CO#1/Flint Housing Commission/Business and Community Services/Increase Abatement of The Atherton East Apartments

Resolution resolving that the appropriate City Officials are hereby to do all things necessary including budget amendments to process a change order to increase contract 19-035 with Flint Housing Commission by \$2,012,100 in the FHUD18CHOICE accounts 296-704.801-529.000 (revenue) and 296-704.801-963.000 (expense) for a revised total contract amount of \$2,568,091.03.

This Matter PASSED on the Consent Agenda

CONSENT AGENDA VOTE

Councilmember Priestley, seconded by Councilmember El-Alamin, made a motion to Approve the Consent Agenda with any separations (Appts. 250056-T, 250039-T, 250057-T, 240523-T, Resos. 250046-T, 250047-T, 250048-T, 250049-T, 250050-T, 250051-T, and 250052-T is a part of the Consent Agenda). This Motion PASSED by the following vote:

Aye: 6 – Councilmember Priestley, Councilmember Winfrey-Carter, Councilmember Mushatt, Councilmember Jarrett, Councilmember El-Alamin, and Councilmember Lewis

No: 0 –

Absent: Councilmembers Burns, and Councilmember Pfeiffer

SEPARATED FROM MASTER RESOLUTION (CONSENT AGENDA)

250053-T Appointment/Board of Review/Karen E. Spencer-Kea/6th Ward

Resolution resolving that the Flint City Council approves the appointment of Karen E. Spencer-Kea (1012 Fremont Street, Flint, Michigan, 48504) to the Board of Review, as 6th Ward representative, for a 3 year term commencing upon adoption of this resolution and expiring 6-1-2028.

**A motion was made by Councilmember Priestley, seconded by Councilmember El-Alamin, that this matter be APPROVED. No votes taken.*

**A motion was made by Councilmember Mushatt, seconded by Councilmember Priestley, to CALL TO THE QUESTION. This motion PASSED by the following vote:*

Aye: 5 – Councilmember Burns, Councilmember Mushatt, Councilmember El-Alamin, Councilmember Lewis, and Councilmember Priestley

No: 2 – Councilmember Winfrey-Carter, and Councilmember Jarrett

Absent: Councilmember Pfeiffer

**A motion was made by Councilmember Priestley, seconded by Councilmember El-Alamin, that this matter be APPROVED. This motion PASSED by the following*

vote:

Aye: 7 – Councilmember Burns, Councilmember Mushatt, Councilmember Jarrett, Councilmember El-Alamin, Councilmember Lewis, Councilmember Priestley, and Winfrey-Carter

No: 0 –

Absent: Councilmember Pfeiffer

250055-T Appointment/City-Wide Advisory Council/Joshua J. Moore/4th Ward

Resolution resolving that the Flint City Council approves the appointment of Joshua J. Moore (1726 Illinois Avenue, Flint Michigan 48506), to fill the 4th Ward seat on the City-Wide Advisory Council (CWAC), as requested by the 4th Ward Flint City Councilmember Judy Priestley, for a term of 3-1-2025 , to 2-28-2028 .

**A motion was made by Councilmember Priestley, seconded by Councilmember El-Alamin, that this matter be APPROVED. No votes taken.*

**A motion was made by Councilmember Mushatt, seconded by Councilmember El-Alamin, to CALL TO THE QUESTION. This motion FAILED by the following vote:*

Aye: 4 – Councilmember Mushatt, Councilmember El-Alamin, Councilmember Lewis, and Councilmember Priestley

No: 3 – Councilmember Winfrey-Carter, Councilmember Burns, and Councilmember Jarrett

Absent: Councilmember Pfeiffer

**A motion was made by Councilmember Priestley, seconded by Councilmember El-Alamin, that this matter be APPROVED. This motion PASSED by the following vote:*

Aye: 7 – Councilmember Jarrett, Councilmember El-Alamin, Councilmember Lewis, Councilmember Priestley, Councilmember Winfrey-Carter, Councilmember

Burns, and Councilmember Mushatt

No: 0 –

Absent: Councilmember Pfeiffer

CONSIDERATION OF APPLICANTS (CANDIDATES) - 3RD WARD COUNCILMEMBER

Consideration of Applicants/Candidates Regarding the Vacancy in the Office of 3rd Ward Council Member, per Flint City Charter Section 2-410(B).

CURRENT APPLICANTS/CANDIDATES:

1. Beverly L. Biggs-Leavy
2. AC Dumas
3. Richard F. Jones
4. Kerry L. Nelson

This Consideration of Applicants will continue for a total of thirty (30) rounds of council members' roll call votes for candidates. By the 15th round, if the council body has not reached a majority vote for any one candidate, each council member will be allowed three (3) minutes in total to discuss their reasoning for supporting or opposing each candidate. The consideration roll call will then continue until the 30th round.

The rounds proceeded as follows:

ROUND #1

X El-Alamin @ Nelson

Lewis @ Nelson

Priestley @ Nelson

Winfrey-Carter @ Biggs-Leavy

Burns @ Biggs-Leavy

Mushatt @ Nelson

Pfeiffer @ ABSENT

Jarrett @ Biggs-Leavy

ROUND #2

- El-Alamin @ Nelson
- Lewis @ Nelson
- Priestley @ Nelson
- Winfrey-Carter @ Biggs-Leavy
- Burns @ Biggs-Leavy
- Mushatt @ Nelson
- Pfeiffer @ ABSENT
- Jarrett @ Biggs-Leavy

ROUND #3

- El-Alamin @ Nelson
- Lewis @ Nelson
- Priestley @ Nelson
- Winfrey-Carter @ Biggs-Leavy
- Burns @ Biggs-Leavy
- Mushatt @ Nelson
- Pfeiffer @ ABSENT
- Jarrett @ Biggs-Leavy

ROUND #4

- El-Alamin @ Nelson
- Lewis @ Nelson
- Priestley @ Nelson
- Winfrey-Carter @ Biggs-Leavy
- Burns @ ABSTAIN
- Mushatt @ Nelson
- Pfeiffer @ ABSENT

Jarrett @ Biggs-Leavy

ROUND #5

El-Alamin @ Nelson

Lewis @ Nelson

Priestley @ Nelson

Winfrey-Carter @ Biggs-Leavy

Burns @ ABSTAIN

Mushatt @ Nelson

Pfeiffer @ ABSENT

Jarrett @ Biggs-Leavy

ROUND #6

El-Alamin @ Nelson

Lewis @ Nelson

Priestley @ Nelson

Winfrey-Carter @ Biggs-Leavy

Burns @ ABSTAIN

Mushatt @ Nelson

Pfeiffer @ ABSENT

Jarrett @ Biggs-Leavy

ROUND #7

El-Alamin @ Nelson

Lewis @ Nelson

Priestley @ Nelson

Winfrey-Carter @ Biggs-Leavy

Burns @ ABSTAIN

Mushatt @ Nelson

- Pfeiffer @ ABSENT
- X Jarrett @ Biggs-Leavy

ROUND #8

- X El-Alamin @ Nelson
- Lewis @ Nelson
- Priestley @ Nelson
- Winfrey-Carter @ Biggs-Leavy
- Burns @ ABSTAIN
- Mushatt @ Nelson
- Pfeiffer @ ABSENT
- Jarrett @ Biggs-Leavy

ROUND #9

- El-Alamin @ Nelson
- X Lewis @ Nelson
- Priestley @ Nelson
- Winfrey-Carter @ Biggs-Leavy
- Burns @ ABSTAIN
- Mushatt @ Nelson
- Pfeiffer @ ABSENT
- Jarrett @ Biggs-Leavy

ROUND #10

- El-Alamin @ Nelson
- Lewis @ Nelson
- X Priestley @ Nelson
- Winfrey-Carter @ Biggs-Leavy
- Burns @ ABSTAIN

- Mushatt @ Nelson
- Pfeiffer @ ABSENT
- Jarrett @ Biggs-Leavy

ROUND #11

- El-Alamin @ Nelson
- Lewis @ Nelson
- Priestley @ Nelson
- X Winfrey-Carter @ Biggs-Leavy
- Burns @ ABSTAIN
- Mushatt @ Nelson
- Pfeiffer @ ABSENT
- Jarrett @ Biggs-Leavy

ROUND #12

- El-Alamin @ Nelson
- Lewis @ Nelson
- Priestley @ Nelson
- Winfrey-Carter @ Biggs-Leavy
- X Burns @ ABSTAIN
- Mushatt @ Nelson
- Pfeiffer @ ABSENT
- Jarrett @ Biggs-Leavy

ROUND #13

- El-Alamin @ Nelson
- Lewis @ Nelson
- Priestley @ Nelson
- Winfrey-Carter @ Biggs-Leavy

Burns @ ABSTAIN

X Mushatt @ Nelson

Pfeiffer @ ABSENT

Jarrett @ Biggs-Leavy

ROUND #14

El-Alamin @ Nelson

Lewis @ Nelson

Priestley @ Nelson

Winfrey-Carter @ Biggs-Leavy

Burns @ ABSTAIN

Mushatt @ Nelson

Pfeiffer @ ABSENT

X Jarrett @ Biggs-Leavy

ROUND #15

X El-Alamin @ Nelson

Lewis @ Nelson

Priestley @ Nelson

Winfrey-Carter @ Biggs-Leavy

Burns @ ABSTAIN

Mushatt @ Nelson

Pfeiffer @ ABSENT

Jarrett @ Biggs-Leavy

DISCUSSION

By the fifteenth (15th) round, if the council body has not reached a majority vote for any one candidate, each council member will have three (3) minutes in total to discuss their reasoning for supporting or opposing each candidate.

HELD

ROUND #16

- El-Alamin @ Nelson
- Lewis @ Nelson
- Priestley @ Nelson
- Winfrey-Carter @ Biggs-Leavy
- Burns @ NOT IN
- Mushatt @ Nelson
- Pfeiffer @ ABSENT
- Jarrett @ Biggs-Leavy

ROUND #17

- El-Alamin @ Nelson
- Lewis @ Nelson
- Priestley @ Nelson
- Winfrey-Carter @ Biggs-Leavy
- Burns @ NOT IN
- Mushatt @ Nelson
- Pfeiffer @ ABSENT
- Jarrett @ Biggs-Leavy

ROUND #18

- El-Alamin @ Nelson
- Lewis @ Nelson
- Priestley @ Nelson
- Winfrey-Carter @ Biggs-Leavy
- Burns @ NOT IN
- Mushatt @ Nelson
- Pfeiffer @ ABSENT

Jarrett @ Biggs-Leavy

ROUND #19

El-Alamin @ Nelson

Lewis @ Nelson

Priestley @ Nelson

Winfrey-Carter @ Biggs-Leavy

X Burns @ ABSENT

Mushatt @ Nelson

Pfeiffer @ ABSENT

Jarrett @ Biggs-Leavy

ROUND #20

El-Alamin @ Nelson

Lewis @ Nelson

Priestley @ Nelson

Winfrey-Carter @ Biggs-Leavy

Burns @ ABSENT

X Mushatt @ Nelson

Pfeiffer @ ABSENT

Jarrett @ Biggs-Leavy

ROUND #21

El-Alamin @ Nelson

Lewis @ Nelson

Priestley @ Nelson

Winfrey-Carter @ Biggs-Leavy

Burns @ ABSENT

Mushatt @ Nelson

- Pfeiffer @ ABSENT
- X Jarrett @ Biggs-Leavy

ROUND #22

- X El-Alamin @ Nelson
- Lewis @ Nelson
- Priestley @ Nelson
- Winfrey-Carter @ Biggs-Leavy
- Burns @ ABSENT
- Mushatt @ Nelson
- Pfeiffer @ ABSENT
- Jarrett @ Biggs-Leavy

ROUND #23

- El-Alamin @ Nelson
- X Lewis @ Nelson
- Priestley @ Nelson
- Winfrey-Carter @ Biggs-Leavy
- Burns @ ABSENT
- Mushatt @ Nelson
- Pfeiffer @ ABSENT
- Jarrett @ Biggs-Leavy

ROUND #24

- El-Alamin @ Nelson
- Lewis @ Nelson
- X Priestley @ Nelson
- Winfrey-Carter @ Biggs-Leavy
- Burns @ ABSENT

- Mushatt @ Nelson
- Pfeiffer @ ABSENT
- Jarrett @ Biggs-Leavy

ROUND #25

- El-Alamin @ Nelson
- Lewis @ Nelson
- Priestley @ Nelson
- X Winfrey-Carter @ Biggs-Leavy
- Burns @ ABSENT
- Mushatt @ Nelson
- Pfeiffer @ ABSENT
- Jarrett @ Biggs-Leavy

ROUND #26

- El-Alamin @ Nelson
- Lewis @ Nelson
- Priestley @ Nelson
- Winfrey-Carter @ Biggs-Leavy
- Burns @ ABSENT
- X Mushatt @ Nelson
- Pfeiffer @ ABSENT
- Jarrett @ Biggs-Leavy

ROUND #27

- El-Alamin @ Nelson
- Lewis @ Nelson
- Priestley @ Nelson
- Winfrey-Carter @ Biggs-Leavy

- Burns @ ABSENT
- Mushatt @ Nelson
- Pfeiffer @ ABSENT
- X Jarrett @ Biggs-Leavy

ROUND #28

- X El-Alamin @ Nelson
- Lewis @ Nelson
- Priestley @ Nelson
- Winfrey-Carter @ Biggs-Leavy
- Burns @ ABSENT
- Mushatt @ Nelson
- Pfeiffer @ ABSENT
- Jarrett @ Biggs-Leavy

ROUND #29

- El-Alamin @ Nelson
- X Lewis @ Nelson
- Priestley @ Nelson
- Winfrey-Carter @ Biggs-Leavy
- Burns @ ABSENT
- Mushatt @ Nelson
- Pfeiffer @ ABSENT
- Jarrett @ Biggs-Leavy

ROUND #30

- El-Alamin @ Nelson
- Lewis @ Nelson
- X Priestley @ Nelson

- Winfrey-Carter @ Biggs-Leavy
- Burns @ ABSENT
- Mushatt @ Nelson
- Pfeiffer @ ABSENT
- Jarrett @ Biggs-Leavy

ORGANIZATION OF THE CITY COUNCIL (Council President)

CALL TO ORDER (President-Elect)

ORGANIZATION OF THE CITY COUNCIL (Council Vice President)

**ORGANIZATION OF THE CITY COUNCIL (Other Officers and
Committees)**

FINAL COUNCIL COMMENTS

ADJOURNMENT

Councilmember Priestley, seconded by Councilmember El-Alamin, made a motion to Adjourn. This City Council Meeting Adjourned at 6:29 p.m.

This Motion PASSED by a VOTE of 5:0.

Absent (Councilmembers Winfrey-Carter, Burns, and Pfeiffer)

Respectfully transcribed and submitted,

*Jasmine Green
City Council Secretary*



250077-T

City of Flint, Michigan

Third Floor, City Hall
1101 S. Saginaw Street
Flint, Michigan 48502
www.cityofflint.com

Meeting Minutes – FINAL

Wednesday, March 5, 2025

5:06 PM

City Council Chambers

FINANCE COMMITTEE

Judy Priestley, Chairperson, Ward 4

Leon El-Alamin, Ward 1

VACANT, Ward 3

Tonya Burns, Ward 6

Dennis Pfeiffer, Ward 8

Ladel Lewis, Ward 2

Jerri Winfrey-Carter, Ward 5

Candice Mushatt, Ward 7

Jonathan Jarrett, Ward 9

Davina Donahue, City Clerk

ROLL CALL

Present: Councilmembers El-Alamin, Priestley, Winfrey-Carter, Burns, Mushatt, Pfeiffer and Jarrett

Absent: Councilmember Lewis

REQUEST FOR AGENDA CHANGES/ADDITIONS

Chairperson Priestley brought to the floor two Add-ons, Add-on #1 is for \$50,000 of ARPA funding to Franklin Avenue Mission, and Add-on #2 is for \$50,000 of ARPA funding to Eastside Compassionate Mission Center.

PUBLIC COMMENT

COUNCIL RESPONSE

Councilmembers to respond (El-Alamin, Pfeiffer, Winfrey-Carter, Burns, and Mushatt,)

CONSENT AGENDA

RESOLUTIONS

250058-T State of Michigan's MCOLES/Public Safety Academy Assistance Program/Flint Police Department

Resolution resolving that the appropriate City Officials, upon the City Council approval, are authorized to do all things necessary to accept the program funds set forth in the program agreement of the State of Michigan in the amount of \$138,133.45, amend the FY25 budget, appropriate award funding to appropriate revenue and expenditure in future years as long as funds are available from the funder, and abide by the terms and conditions of the award from the State of Michigan. [NOTE: The State of Michigan has awarded the City of Flint Basic Law Enforcement Training Academy Scholarships and salaries for employed recruits.]

This Matter PASSED on the Consent Agenda

250059-T Tri County International Truck, Inc./2025 Truck Chassis

Resolution resolving that The Division of Purchases and Supplies, upon City Council's approval, is hereby authorized to issue a Purchase Order to Tri County International Trucks, Inc. for the purchase of a 2025 International truck chassis, in amount NOT-TO-EXCEED \$151,079.92, for FY25 (07/01/24-06/30/2025). [NOTE: This truck will replace the 1991 International semi-truck that the Sewer Department currently uses, as the current vehicle no longer makes fiscal sense due to its condition and age.]

This Matter PASSED on the Consent Agenda

ADD-ON #1 Reallocation of ARPA Funds/Franklin Avenue Mission/Food Access and Food Support System

Resolution resolving that the appropriate City Officials are hereby authorized to do all things necessary, including executing any necessary agreements, to appropriate \$50,000.00

in funding to Franklin Avenue Mission for Food Access and Food System Support. Before the funds are spent, the City of Flint's ARPA administration, compliance, and implementation firm shall review and ensure compliance with the latest US Department of Treasury final rules.

SEPARATED FROM THE MASTER RESOLUTION

ADD-ON #2 Reallocation of ARPA Funds/Eastside Compassionate Mission Center/Food Access and Food Support System

Resolution resolving that the appropriate City Officials are hereby authorized to do all things necessary, including executing any necessary agreements, to appropriate \$50,000.00 in funding to Eastside Compassionate Mission Center for Food Access and Food System Support. Before the funds are spent, the City of Flint's ARPA administration, compliance, and implementation firm shall review and ensure compliance with the latest US Department of Treasury final rules.

SEPARATED FROM THE MASTER RESOLUTION

CONSENT AGENDA VOTE

Councilmember Mushatt, seconded by Councilmember El-Alamin, made a motion to Approve the Consent Agenda with any separations (Reso. # 250058-T, and 250059-T are a part of the Consent Agenda [SENT TO COUNCIL 3-10-2025]). This Motion PASSED by the following vote:

Aye: 7 – Councilmember Priestley, Councilmember Winfrey-Carter, Councilmember Burns, Councilmember Mushatt, Councilmember Pfeiffer, Councilmember Jarrett, and Councilmember El-Alamin

No: 0 –

Absent: Councilmember Lewis

SEPARATED FROM MASTER RESOLUTION (CONSENT AGENDA)

ADD-ON #1 Reallocation of ARPA Funds/Franklin Avenue Mission/Food Access and Food Support System

Resolution resolving that the appropriate City Officials are hereby authorized to do all things necessary, including executing any necessary agreements, to appropriate \$50,000.00 in funding to Franklin Avenue Mission for Food Access and Food System Support. Before the funds are spent, the City of Flint's ARPA administration, compliance, and

implementation firm shall review and ensure compliance with the latest US Department of Treasury final rules.

**A motion was made by Councilmember Mushatt, seconded by Councilmember El-Alamin, that this matter be sent to COUNCIL (3-10-2025). No Votes were Taken.*

**A motion was made by Councilmember Jarrett, seconded by Councilmember El-Alamin, that this matter be POSTPONED to FINANCE COMMITTEE (3-19-2025). This motion PASSED by the following vote:*

Aye: 6 – Councilmember Priestley, Councilmember Winfrey-Carter, Councilmember Burns, Councilmember Mushatt, Councilmember Jarrett, and Councilmember El-Alamin

No: 1 – Councilmember Pfeiffer

Absent: Councilmember Lewis

ADD-ON #2 Reallocation of ARPA Funds/Eastside Compassionate Mission Center/Food Access and Food Support System

Resolution resolving that the appropriate City Officials are hereby authorized to do all things necessary, including executing any necessary agreements, to appropriate \$50,000.00 in funding to Eastside Compassionate Mission Center for Food Access and Food System Support. Before the funds are spent, the City of Flint's ARPA administration, compliance, and implementation firm shall review and ensure compliance with the latest US Department of Treasury final rules.

**A motion was made by Councilmember Priestley, seconded by Councilmember El-Alamin, that this matter be POSTPONED to FINANCE COMMITTEE (3-19-2025). This motion FAILED by the following vote:*

Aye: 4 – Councilmember Winfrey-Carter, Councilmember Mushatt, Councilmember El-Alamin, and Councilmember Priestley

No: 3 – Councilmember Burns, Councilmember Pfeiffer, and Councilmember Jarrett

Absent: Councilmember Lewis

**A motion was made by Councilmember Priestley, seconded by Councilmember El-*

Alamin, that this matter be sent to COUNCIL (3-10-2025). No Votes were Taken.

**A motion was made by Councilmember Mushatt, seconded by Councilmember Burns, that this matter be SENT TO SPECIAL AFFAIRS (3-10-2025). This motion FAILED by the following vote:*

Aye: 4 – Councilmember Burns, Councilmember Mushatt, Councilmember El-Alamin, and Councilmember Priestley

No: 2 – Councilmember Jarrett, and Councilmember Winfrey-Carter

Absent: Councilmember Lewis, and Councilmember Pfeiffer

RECESS

Chairperson Priestley ordered a 5-minute Recess without Objection.

CALL BACK TO ORDER

Chairperson Priestley Called this Finance Committee back to order at 6:39 p.m.

ROLL CALL

Present: Councilmembers El-Alamin, Priestley, Winfrey-Carter, Burns, Mushatt, Pfeiffer, and Jarrett

Absent: Councilmember Lewis

SEPARATED FROM MASTER RESOLUTION (CONSENT AGENDA) (Continued)

ADD-ON #2 Reallocation of ARPA Funds/Eastside Compassionate Mission Center/Food Access and Food Support System

Resolution resolving that the appropriate City Officials are hereby authorized to do all things necessary, including executing any necessary agreements, to appropriate \$50,000.00 in funding to Eastside Compassionate Mission Center for Food Access and Food System Support. Before the funds are spent, the City of Flint's ARPA administration, compliance, and implementation firm shall review and ensure compliance with the latest US Department of Treasury final rules.

**A motion was made by Councilmember Priestley, seconded by Councilmember El-Alamin, that this matter be SENT TO COUNCIL (3-10-2025). This motion FAILED*

by the following vote:

Aye: 3 – Councilmember Mushatt, Councilmember El-Alamin, and Councilmember Priestley

No: 4 – Councilmember Pfeiffer, Councilmember Jarrett, Councilmember Winfrey-Carter, and Councilmember Burns

Absent: Councilmember Lewis

ADJOURNMENT

Councilmember Pfeiffer, seconded by Councilmember Mushatt, made a motion to Adjourn. This Finance Committee Meeting Adjourned at 6:45 p.m.

This Motion PASSED by a VOTE of 7:0

Absent: (Councilmember Lewis)

Respectfully transcribed and submitted,

*Jasmine Green
City Council Secretary*



250078-T

City of Flint, Michigan

Third Floor, City Hall
1101 S. Saginaw Street
Flint, Michigan 48502
www.cityofflint.com

Meeting Minutes – FINAL

Wednesday, March 5, 2025

6:51 PM

City Council Chambers

GOVERNMENTAL OPERATIONS COMMITTEE

VACANT, Chairperson

Leon El-Alamin, Ward 1

Ladel Lewis, Ward 2

VACANT, Ward 3

Judy Priestley, Ward 4

Jerri Winfrey-Carter, Ward 5

Tonya Burns, Ward 6

Candice Mushatt, Ward 7

Dennis Pfeiffer, Ward 8

Jonathan Jarrett, Ward 9

Davina Donahue, City Clerk

ROLL CALL

Present: Councilmembers El-Alamin, Priestley, Winfrey-Carter, Burns, Mushatt, Pfeiffer and Jarrett

Absent: Councilmember Lewis

REQUEST FOR AGENDA CHANGES/ADDITIONS

NONE

PUBLIC COMMENT

COUNCIL RESPONSE

Councilmembers to Respond (Burns, El-Alamin, and Mushatt)

CONSENT AGENDA

RESOLUTIONS

250060-T Memorandum of Understanding (MOU)/Version 2.0/Comprehensive Plan Update/City of Flint Planning Commission

Resolution resolving that the appropriate City officials are authorized to do all things necessary to enact the Memorandum of Understanding (Version 2.0) that is being recommended by the Planning Commission from their November 12th, 2024 meeting. [NOTE: The Imagine Flint Comprehensive Plan ("the Plan"), adopted on October 28, 2013, was reviewed by the Planning Commission (at its February 13th, 2024 regular meeting) per the Michigan Planning Enabling Act, P.A. 33 of 2008, as amended, MCL 125.3801 *et seq.*, and the determination was made that an update was needed. Part of the creation of the plan included an MOU between the City of Flint, City of Flint Planning Commission, and City Council for City of Flint to define roles and responsibilities between the partnering entities. The Administration would now like to enact an updated MOU to define the roles of the Planning Commission, Steering Committee, Department of Business and Community Services, City Administration, and the City Council in the Plan update process.]

SEPARATED FROM THE MASTER RESOLUTION

APPOINTMENTS

250061-T Re-Appointment/Hurley Board of Hospital Managers/Charlotte Edwards

Resolution resolving that the Flint City Council approves the re-appointment of Charlotte Edwards (Flint, Michigan, 48503) to the Hurley Board of Hospital Managers, with such term commencing immediately and expiring on April 30, 2030.

SEPARATED FROM THE MASTER RESOLUTION

250062-T Re-Appointment/Hurley Board of Hospital Managers/DeAndra Larkin

Resolution resolving that the Flint City Council approves the re-appointment of DeAndra Larkin (Flint, Michigan, 48507) to serve a five-year term on the Hurley

Board of Hospital Managers, with such term commencing immediately and expiring on April 30, 2030.

SEPARATED FROM THE MASTER RESOLUTION

250063-T Appointment/Hurley Board of Hospital Managers/Dr. Khalid M. Ahmed

Resolution resolving that the Flint City Council approves the appointment of Dr. Khalid M. Ahmed (Flint, Michigan, 48503) to serve a five-year term on the Hurley Board of Hospital Managers, with such term commencing immediately and expiring on April 30, 2030.

SEPARATED FROM THE MASTER RESOLUTION

250064-T Appointment/Ethics and Accountability Board/Christopher A Utech/4th Ward

Resolution resolving that the Flint City Council approves the appointment of Christopher A. Utech (Flint, Michigan, 48506 – Ward 4) to the Ethics and Accountability Board to fill a 4th Ward vacancy, for two (2) year term, with such term commencing _____ and expiring _____, as recommended by 4th Ward Councilmember Judy Priestley.

SEPARATED FROM THE MASTER RESOLUTION

CONSENT AGENDA VOTE

Councilmember Priestley, seconded by Councilmember El-Alamin, made a motion to Approve the Consent Agenda with any separations (SEND TO COUNCIL). Every agenda item were separated. No votes taken.

SEPARATED FROM MASTER RESOLUTION (CONSENT AGENDA)

250060-T Memorandum of Understanding (MOU)/Version 2.0/Comprehensive Plan Update/City of Flint Planning Commission

Resolution resolving that the appropriate City officials are authorized to do all things necessary to enact the Memorandum of Understanding (Version 2.0) that is being recommended by the Planning Commission from their November 12th, 2024 meeting. [NOTE: The Imagine Flint Comprehensive Plan (“the Plan”), adopted on October 28, 2013, was reviewed by the Planning Commission (at its February 13th, 2024 regular meeting) per the Michigan Planning Enabling Act, P.A. 33 of 2008, as amended, MCL 125.3801 *et seq.*, and the determination was made that an update was needed. Part of the creation of the plan included an MOU between the City of Flint, City of Flint Planning Commission, and City Council for City of Flint to define roles and responsibilities between the partnering entities. The Administration would

now like to enact an updated MOU to define the roles of the Planning Commission, Steering Committee, Department of Business and Community Services, City Administration, and the City Council in the Plan update process.]

**A motion was made by Councilmember Priestley, seconded by Councilmember El-Alamin, that this matter be SENT TO COUNCIL (3-10-2025). This motion FAILED by the following vote:*

Aye: 2 – Councilmember Priestley, and Councilmember Mushatt

No: 5 – Councilmember El-Alamin, Councilmember Winfrey-Carter, Councilmember Burns, Councilmember Pfeiffer, and Councilmember Jarrett

Absent: Councilmember Lewis

250061-T Re-Appointment/Hurley Board of Hospital Managers/Charlotte Edwards

Resolution resolving that the Flint City Council approves the re-appointment of Charlotte Edwards (Flint, Michigan, 48503) to the Hurley Board of Hospital Managers, with such term commencing immediately and expiring on April 30, 2030.

**A motion was made by Councilmember Winfrey-Carter, seconded by Councilmember Burns, that this matter be sent to COUNCIL (3-10-2025). No Votes were Taken.*

**A motion was made by Councilmember Pfeiffer, seconded by Councilmember Burns, that this matter STAY IN GOVERNMENTAL OPERATIONS COMMITTEE (3-19-2025). This motion PASSED by the following vote:*

Aye: 6 – Councilmember Priestley, Councilmember Burns, Councilmember Mushatt, Councilmember Pfeiffer, Councilmember Jarrett, and Councilmember El-Alamin

No: 1 – Councilmember Winfrey-Carter

Absent: Councilmember Lewis

250062-T Re-Appointment/Hurley Board of Hospital Managers/DeAndra Larkin

Resolution resolving that the Flint City Council approves the re-appointment of DeAndra Larkin (Flint, Michigan, 48507) to serve a five-year term on the Hurley

Board of Hospital Managers, with such term commencing immediately and expiring on April 30, 2030.

**A motion was made by Councilmember Priestley, seconded by Councilmember El-Alamin, that this matter be sent to COUNCIL (3-10-2025). No Votes were Taken.*

**A motion was made by Councilmember Pfeiffer, seconded by Councilmember Priestley, that this matter be POSTPONED INDEFINITELY. This motion PASSED by the following vote:*

Aye: 7 – Councilmember Winfrey-Carter, Councilmember Burns, Councilmember Mushatt, Councilmember Pfeiffer, Councilmember Jarrett, Councilmember El-Alamin, and Councilmember Priestley

No: 0 –

Absent: Councilmember Lewis

250063-T Appointment/Hurley Board of Hospital Managers/Dr. Khalid M. Ahmed

Resolution resolving that the Flint City Council approves the appointment of Dr. Khalid M. Ahmed (Flint, Michigan, 48503) to serve a five-year term on the Hurley Board of Hospital Managers, with such term commencing immediately and expiring on April 30, 2030.

**A motion was made by Councilmember Priestley, seconded by Councilmember El-Alamin, that this matter be POSTPONED INDEFINITELY. This motion PASSED by the following vote:*

Aye: 6 – Councilmember Mushatt, Councilmember Pfeiffer, Councilmember Jarrett, Councilmember El-Alamin, Councilmember Priestley, and Councilmember Winfrey-Carter

No: 1 – Councilmember Burns

Absent: Councilmember Lewis

250064-T Appointment/Ethics and Accountability Board/Christopher A Utech/4th Ward

Resolution resolving that the Flint City Council approves the appointment of Christopher A. Utech (Flint, Michigan, 48506 – Ward 4) to the Ethics and

Accountability Board to fill a 4th Ward vacancy, for two (2) year term, with such term commencing _____ and expiring _____, as recommended by 4th Ward Councilmember Judy Priestley.

**A motion was made by Councilmember Priestley, seconded by Councilmember El-Alamin, that this matter be sent to COUNCIL (3-10-2025). No Votes were Taken.*

**A motion was made by Councilmember Mushatt, seconded by Councilmember Priestley, that this matter be POSTPONED to GOVERNMENTAL OPERATIONS COMMITTEE (3-19-2025). This motion FAILED by the following vote:*

Aye: 2 – Councilmember Mushatt, and Councilmember Priestley

No: 5 – Councilmember Pfeiffer, Councilmember Jarrett, Councilmember El-Alamin, Councilmember Winfrey-Carter, Councilmember Burns

Absent: Councilmember Lewis

**A motion was made by Councilmember Priestley, seconded by Councilmember El-Alamin, that this matter be sent to COUNCIL (3-10-2025). This motion FAILED by the following vote:*

Aye: 2 – Councilmember Mushatt, and Councilmember Priestley

No: 5 – Councilmember Pfeiffer, Councilmember Jarrett, Councilmember El-Alamin, Councilmember Winfrey-Carter, and Councilmember Burns

Absent: Councilmember Lewis

ADJOURNMENT

Councilmember Priestley, seconded by Councilmember El-Alamin, made a motion to Adjourn. This Governmental Operations Committee Meeting Adjourned at 8:00 p.m.

This Motion PASSED by a VOTE of 7:0

Absent: (Lewis)

Respectfully transcribed and submitted,

*Jasmine Green
City Council Secretary*



250079-T

City of Flint, Michigan

Third Floor, City Hall
1101 S. Saginaw Street
Flint, Michigan 48502
www.cityofflint.com

Meeting Minutes – FINAL

Wednesday, March 5, 2025

City Council Chambers

LEGISLATIVE COMMITTEE

VACANT, Chairperson

Leon El-Alamin, Ward 1

Ladel Lewis, Ward 2

VACANT, Ward 3

Judy Priestley, Ward 4

Jerri Winfrey-Carter, Ward 5

Tonya Burns, Ward 6

Candice Mushatt, Ward 7

Dennis Pfeiffer, Ward 8

Jonathan Jarrett, Ward 9

Davina Donahue, City Clerk

CANCELLED MEETING

ROLL CALL

REQUEST FOR AGENDA CHANGES/ADDITIONS

PUBLIC COMMENT

COUNCIL RESPONSE

CONSENT AGENDA

ORDINANCES

ADJOURNMENT

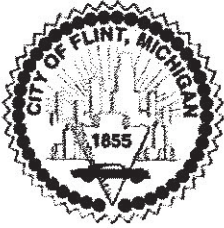

RESOLUTION NO.: 250058-T

PRESENTED: 3-5-2025

ADOPTED: _____

**RESOLUTION TO ACCEPT THE STATE OF MICHIGAN'S MCOLES
PUBLIC SAFETY ACADEMY ASSISTANCE PROGRAM**

BY THE CITY ADMINISTRATOR:

WHEREAS, the State of Michigan has awarded the City of Flint for City of Flint Basic Law Enforcement Training Academy scholarships and salaries for employed recruits.

WHEREAS, the City of Flint had been awarded in the amount of \$138,133.45 for the City of Flint Police department to use for Basic Law Enforcement Training Academy scholarships and salaries for employed recruits.

WHEREAS, the funds will be utilized in compliance with the program agreement and approved program budget through the end of the program;

IT IS RESOLVED, that the appropriate City officials, upon the City Council approval, are authorized to do all things necessary to accept the program funds set forth in the program agreement of the State of Michigan in the amount of \$138,133.45, amend the FY25 budget, appropriate award funding to appropriate revenue and expenditure in future years as long as the funds are available from the funder, and abide by the terms and conditions of the award from the State of Michigan.

APPROVED AS TO FORM:

JoAnne Gurley
JoAnne Gurley (Feb 14, 2025 15:41 EST)

Joanne Gurley, Chief Legal Officer

APPROVED AS TO FINANCE:

Phillip Moore
Phillip Moore (Feb 17, 2025 08:55 EST)

Phillip Moore, Chief Financial Officer

FOR THE CITY OF FLINT:

Clyde D. Edwards / A0398
Clyde D. Edwards / A0398 (Feb 24, 2025 12:54 EST)

Clyde D. Edwards, City Administrator

APPROVED BY CITY COUNCIL:

City Council



CITY OF FLINT

**** STAFF REVIEW FORM ****

October 9, 2024

TODAY'S DATE: 2/11/2025

BID/PROPOSAL# N/A

AGENDA ITEM TITLE: TO ACCEPT THE STATE OF MICHIGAN'S MCOLES PUBLIC SAFETY ACADEMY ASSISTANCE PROGRAM

PREPARED BY: Angela Amerman

VENDOR NAME: State of Michigan

Section I: BACKGROUND/SUMMARY OF PROPOSED ACTION:

The Police Department is requesting approval for the acceptance of \$138,133.45 from the State of Michigan to use for Basic Law Enforcement Training Academy scholarships and salaries for employed recruits.

Section II. PREVIOUS ALLOCATIONS (INCLUDE ALL ACCOUNTS USED FOR THIS PURPOSE)/ PROVIDE RESOLUTION OR CONTRACT INFORMATION THAT APPLIES

Fiscal Year	Account	FY GL Allocation	FY PO Amount	FY Expensed	Resolution
FY23	296-326.100-686.060	\$16,000.00		\$16,000.00	230110
FY23	296-326.100-686.060	\$35,877.40		\$35,877.40	230168
FY24	296-326.100-686.060	\$192,000.00		\$161,564.65	230408
FY24	296-326.100-686.060	\$117,871.80		\$113,266.10	240114



CITY OF FLINT

**** STAFF REVIEW FORM ****

October 9, 2024

BUDGET YEAR 2

BUDGET YEAR 3

OTHER IMPLICATIONS (i.e., collective bargaining):

PRE-ENCUMBERED? YES NO REQUISITION NO:

ACCOUNTING APPROVAL: *[Signature]* Date: _____

WILL YOUR DEPARTMENT NEED A CONTRACT? YES NO

Section V: RESOLUTION DEFENSE TEAM:

(Places of the names of those who can defend this resolution at City Council)

	NAME	PHONE NUMBER
1	Terence Green	
2	Jeff Antcliff	
3	Ronald Dixon	

STAFF RECOMMENDATION: (PLEASE SELECT): APPROVED NOT APPROVED

DEPARTMENT HEAD SIGNATURE: *Terence Green*
Terence Green (Feb 11, 2025 16:02 EST)
(Terence Green, Police Chief)

ADMINISTRATION APPROVAL: *[Signature]*
Clyde D. Edwards (Feb 12, 2025 11:33 EST)



GRETCHEN WHITMER
GOVERNOR

STATE OF MICHIGAN
MICHIGAN COMMISSION ON LAW ENFORCEMENT STANDARDS
LANSING

TIMOTHY S. BOURGEOIS
EXECUTIVE DIRECTOR

January 30, 2025

Sergeant Dominic Tefft
Flint Police Department
dtefft@cityofflint.com

Re: MCOLES Public Safety Academy Assistance Program

Dear Sergeant Tefft,

This letter is to advise you that the Michigan Commission on Law Enforcement Standards (MCOLES) has completed a review of the applications for Recruits Charles Besson, Logan Campbell, Tekeveiohn Evans, Brenna Glazier, Tristen Hoy-Johnson, Amir James, Stephanie Rau-Waterman for the MCOLES Public Safety Academy Assistance Program. We have determined that these employed recruits meet the criteria to qualify for the program. The following payment to the agency has been initiated:

<u>Recruit Name</u>	<u>Agency Stipend for Salary/Wages</u>	<u>Additional Allowable Expenses</u>	<u>Total Tuition</u>	<u>TOTAL Approved Payment</u>	<u>Document #</u>
Charles Besson	12,984.35	740.00	5,925.00	19733.35	GAX 25*45923
Logan Campbell	12,984.35	740.00	5,925.00	19733.35	GAX 25*45923
Tekeveiohn Evans	12,984.35	740.00	5,925.00	19733.35	GAX 25*45923
Brenna Glazier	12,984.35	740.00	5,925.00	19733.35	GAX 25*45923
Tristen Hoy-Johnson	12,984.35	740.00	5,925.00	19733.35	GAX 25*45923
Amir James	12,984.35	740.00	5,925.00	19733.35	GAX 25*45923
Stephanie Rau-Waterman	12,984.35	740.00	5,925.00	19733.35	GAX 25*45923

Director Kimberly Koster, Chair • Sheriff Anthony Wickersham, Vice-Chair • Lt. Col. Michael A. Krumm representing Col. James F. Grady II
Deputy Matthew Hartig • Mr. Michael Wendling • Mr. David Tanay representing Attorney General Dana Nessel • Officer Linda Broden • Tpr. Nate Johnson
Mr. Arthur Weiss • Second Assistant Chief Grant Ha representing Chief James E. White • Ms. Chianta Lymon • Dr. Lisa R. Jackson • Lt. Michael Hawkins
Mr. Kenneth Grabowski • Mr. Michael Sauger • Sheriff Matthew Saxton • Mr. James Stachowski • Deputy Director Ronald Wiles • Chief Issa Shahin
Pastor Tellis J. Chapman • Pastor Jeffery A. Hawkins • Sheriff Gregory Zyburt • Mr. Anthony D. Lewis representing Mr. John E. Johnson

927 Centennial Way
Lansing, MI 48913
www.michigan.gov/mcoles
517-636-7864

This payment is for the agency stipend for the employed recruit's salary, any additional allowable expenses included in the application, academy tuition, and \$84 for the licensing exam fee, *up to* \$20,000.00, as allowed through the program. If the recruit withdraws from the academy session or resigns from the agency prior to expending the full \$20,000.00, the balance shall be returned to MCOLES and applied back to the scholarship fund.

Following this application approval by MCOLES, the basic law enforcement training program will invoice your agency directly for the eligible expenses related to the recruit's academy session.

Please note that agencies would not also receive Training to Locals (TTL) reimbursements for employed recruits funded through this program.

If you have any questions, please contact MCOLES at MSP-MCOLES-Grants@michigan.gov.

Sincerely,

Cristina Dowker
Grants and Contracts Manager



RESOLUTION NO.: 250059-T
 PRESENTED: 3-5-2025
 ADOPTED: _____

BY THE CITY ADMINISTRATOR:

RESOLUTION TO TRI COUNTY INTERNATIONAL TRUCK, INC. FOR THE PURCHASE OF A 2025 TRUCK CHASSIS

The City of Flint Sewer Department, Utilities Division, requests a purchase order be issued to Tri County International Trucks Inc. for the purchase of an International truck chassis. This truck will replace the 1999 International semi-truck that the sewer department currently uses. The current vehicle no longer makes fiscal sense due to its condition and age.

This is a qualified purchase under the State of Michigan DTMB Contract #240000000096, Specification #3958 0179D. There is adequate funding for said purchases from the listed accounts:

590-540.208-863.000	Vehicle & Equipment Charges	\$151,079.92
---------------------	-----------------------------	--------------

IT IS RESOLVED, that The Division of Purchases and Supplies, upon City Council's approval, is hereby authorized to issue a Purchase Order to Tri County International Trucks, Inc. for the purchase of a 2025 International truck chassis in an amount not to exceed \$151,079.92 for FY25 (07/01/24-06/30/2025).

FOR THE CITY OF FLINT:

APPROVED BY CITY COUNCIL:

Clyde D. Edwards / AD399
Clyde D. Edwards / AD399 (Feb 27, 2025 10:16 EST)
Clyde Edwards, City Administrator

APPROVED AS TO FORM:

APPROVED AS TO FINANCE:

JoAnne Gurley
JoAnne Gurley (Feb 27, 2025 19:09 EST)
Joanne Gurley, City Attorney

Phillip Moore
Phillip Moore (Feb 27, 2025 08:10 EST)
Phillip Moore, Chief Financial Officer

APPROVED AS TO PURCHASING:

Lauren Rowley
Lauren Rowley, Purchasing Manager



CITY OF FLINT

**** STAFF REVIEW FORM ****

October 9, 2024

TODAY'S DATE: February 20, 2025

BID/PROPOSAL#

AGENDA ITEM TITLE: Semi Truck Purchase

PREPARED BY: Cheri Priest for Entrice Mitchell, Sewer Systems Supervisor

VENDOR NAME: Tri County International Trucks

Section I: BACKGROUND/SUMMARY OF PROPOSED ACTION:

The sewer department requests a purchase order be issued to Tri County International Truck for the purchase of a 2025 International semi-truck. This purchase will replace the 1999 International truck that the sewer department currently uses. This truck is well past its life expectancy. We are unable to properly DOT this vehicle due to the large amount of repairs needed. The sewer department had to sign an agreement to purchase this vehicle in mid-2024 in order for the truck to be ordered for us. It was explained that the manufacturer gets a set number of chips for their trucks per year and if we did not place an order we would not be able to get one. They only manufacture the number of vehicles that they have orders for. This purchase was originally supposed to come approximately August 2025 and would have come out of next year's equipment allotment. The truck is coming earlier than expected, March 2025, and we will reconfigure our purchase requests for next fiscal year.

This vehicle will be purchased under the State of Michigan DTMB Contract #240000000096, Specification #3958 0178D. See attached vehicle specifications.

Section II. PREVIOUS ALLOCATIONS (INCLUDE ALL ACCOUNTS USED FOR THIS PURPOSE)/ PROVIDE RESOLUTION OR CONTRACT INFORMATION THAT APPLIES

Fiscal Year	Account	FY GL Allocation	FY PO Amount	FY Expensed	Resolution
2025	New Vendor				



CITY OF FLINT

**** STAFF REVIEW FORM ****

October 9, 2024

[Empty rectangular box]

Section III.

POSSIBLE BENEFIT TO THE CITY OF FLINT (RESIDENTS AND/OR CITY OPERATIONS) INCLUDE PARTNERSHIPS AND COLLABORATIONS:

This vehicle purchase allows the sewer department to more effectively transport their large equipment around to various job sites throughout the City. The cost to maintain this vehicle no longer makes fiscal sense due to the condition and age of the vehicle.

Section IV: FINANCIAL IMPLICATIONS:

IF ARPA related Expenditure:

Has this request been reviewed by E&Y Firm: YES NO IF NO, PLEASE EXPLAIN:

[Empty rectangular box]

BUDGETED EXPENDITURE? YES X NO IF NO, PLEASE EXPLAIN:

Dept.	Name of Account	Account Number	Grant Code	Amount
2496	590-540.208-863.000	Vehicle & Equipment Charges	N/A	\$151,078.92
		FY25 GRAND TOTAL		\$151,078.92



CITY OF FLINT

**** STAFF REVIEW FORM ****

October 9, 2024

WHEN APPLICABLE, IF MORE THAN ONE (1) YEAR, PLEASE ESTIMATE TOTAL AMOUNT FOR EACH BUDGET YEAR: (This will depend on the term of the bid proposal)

BUDGET YEAR 1 \$

BUDGET YEAR 2

BUDGET YEAR 3

OTHER IMPLICATIONS (i.e., collective bargaining):

PRE-ENCUMBERED? YES NO REQUISITION NO:

ACCOUNTING APPROVAL: Cheri Priest Date: 02/25/2025
Cheri Priest (Feb 25, 2025 10:47 EST)

WILL YOUR DEPARTMENT NEED A CONTRACT? YES NO

Section V: RESOLUTION DEFENSE TEAM:

(Place the names of those who can defend this resolution at City Council)

	NAME	PHONE NUMBER
1	Entrice Mitchell	810-691-4345
2	Kenneth Miller	810-265-6687
3	Marquita Blair	810-423-5650

STAFF RECOMMENDATION: (PLEASE SELECT): APPROVED NOT APPROVED

DEPARTMENT HEAD SIGNATURE: Entrice Mitchell
Entrice Mitchell, Sewer Systems Supervisor

ADMINISTRATION APPROVAL: CDE
Clyde D. Edwards (Feb 26, 2025 14:34 EST)
(for \$20,000 or above spending authorizations) Clyde Edwards, City Administrator

Prepared For:
 CITY OF FLINT
 Jiggy Mitchell
 DEPARTMENT OF PURCH.
 FLINT, MI 48502-
 (810)766 - 7499
 Reference ID: HX620 X15

Presented By:
 TRI COUNTY INTL TRUCKS
 Jeremy Kast
 3001 E HIGH ST
 JACKSON MI 49203
 (517)783-2721

Tri County International Trucks, Inc./State of Michigan DTMB Contract 24000000096, Specification #3958 0178D for a new 2025 MY International Truck Chassis per this proposal. Pricing includes all user specified option equipment costs and available discounts in effect as of date listed. Please note that the afforded pricing includes a 1% fee paid to the state of Michigan as required under this contract. Additional surcharge requirements as issued by the manufacturer may be applicable in the future.

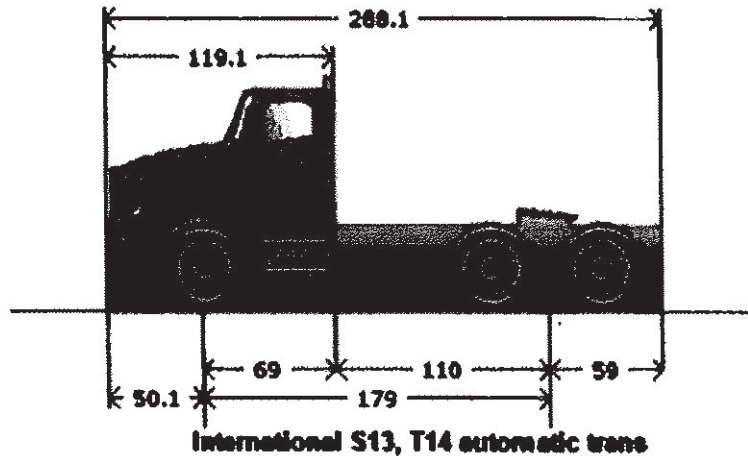

Michigan MI Deal Quote
Model Profile
 2025 HX620 SBA (HX620)

AXLE CONFIG:	6X4
MISSION:	Requested GCWR: 120000. Calc. GCWR: 115000. Calc. GVWR: 64000 Calc. Start / Grade Ability: 12.67% / 1.51% @ 55 MPH Calc. Geared Speed: 77.9 MPH
DIMENSION:	Wheelbase: 179.00, CA: 110.00, Axle to Frame: 59.00
ENGINE, DIESEL:	{Cummins X15 500V} Productivity Series, EPA 2024, 500HP @ 1900 RPM, 1850 lb-ft Torque @ 900 RPM, 2000 RPM Governed Speed, 512 Peak HP (Max)
TRANSMISSION, MANUAL:	{Fuller RTLO-18913A} 13-Speed Manual, Double Overdrive, Air Shift, Internal Lube Oil Pump
CLUTCH:	{Eaton Fuller Advantage} Self-Adjusting, 15.5" Dia Two-Plate, Cast Angle Spring, Ceramic, 7-Spring Coaxial VCT Plus Damper with Pre-Damper, 2"-10 Tooth Spline, Mechanical Pull Type Control, 6-Button Disc, 1860 lb-ft Torque Capacity
AXLE, FRONT NON-DRIVING:	{Meritor MFS-18-133A} Wide Track, I-Beam Type, 18,000-lb Capacity
AXLE, REAR, TANDEN:	{Meritor RT-46-164EH} Single Reduction, Standard Width, 46,000-lb Capacity, Driver Controlled Locking Differential in Forward-Rear and Rear-Rear Axle, 200 Wheel Ends Gear Ratio: 4.30
CAB:	Conventional, Day Cab
TIRE, FRONT:	(2) 385/65R22.5 Load Range L HAC 3 (CONTINENTAL), 479 rev/mile, 68 MPH, All-Position
TIRE, REAR:	(8) 11R22.5 Load Range H HDR2+ (CONTINENTAL), 491 rev/mile, 75 MPH, Drive
SUSPENSION, REAR, AIR, TANDEN:	{Hendrickson HAS-460-55} 46,000-lb Capacity, 55" Axle Spacing, 9.5" Ride Height, with Shock Absorbers, Mounted Inboard
PAINT:	Cab schematic 100LZ Location 1: 2303, Red (Std)

Chassis schematic N/A

Code	Description	F/R Wt (lbs)	Tot Wt (lbs)
HX62000	Base Chassis, Model HX620 SBA with 179.00 Wheelbase, 110.00 CA, and 59.00 Axle to Frame.	9356/6680	16036

AXLE CONFIGURATION

1AND	AXLE CONFIGURATION 6x4	0/0	0
	Notes : Pricing may change if axle configuration is changed.		

ENGINE

12EWZ	ENGINE, DIESEL {Cummins X15 500V} Productivity Series, EPA 2024, 500HP @ 1900 RPM, 1850 lb-ft Torque @ 900 RPM, 2000 RPM Governed Speed, 512 Peak HP (Max)	589/44	633
12VJT	EMISSION, CALENDAR YEAR {Cummins X15} EPA, OBD and GHG Certified for Calendar Year 2024	0/0	0
12XCS	CARB EMISSION WARR COMPLIANCE Does Not Comply with CARB Emission Warranty	0/0	0
12WZE	CARB IDLE COMPLIANCE Does Not Comply with California Clean Air Idle Regulations	0/0	0
12WVH	EPA IDLE COMPLIANCE Low NOx Idle Engine, Complies with EPA Clean Air Regulations; Includes "Certified Clean Idle" Decal on Door	0/0	0
10UAV	VEHICLE REGISTRATION IDENTITY ID for Non-CARB Omnibus and/or Non-ACT Adopting State or Exempt Vehicle. Not for use on vehicles registering in CA/MA /OR/NJ/NY/WA. Contains non-mitigated legacy engine & cannot be registered in CA unless exempt. You may be held liable under state law for failure to properly register vehicle.	0/0	0
	Notes : CANNOT BE REGISTERED IN CA. For vehicles that will be registered in States other than CA.		
12XBC	RADIATOR Aluminum, Welded, Down Flow, Front to Back System, 1325 SqIn, with 806 SqIn Charge Air Cooler	0/0	0
	Includes : RADIATOR HOSES Premium, Rubber		
12THT	FAN DRIVE {Horton Drivemaster} Two-Speed Type, Direct Drive, with Residual Torque Device for Disengaged Fan Speed	0/0	0
	Includes : FAN Nylon		
12VCA	AIR CLEANER Single Element, with Pre-Cleaner, Engine Mounted	0/0	0
12703	ANTI-FREEZE Red, Extended Life Coolant; To -40 Degrees F/ -40 Degrees C, Freeze Protection	0/0	0
12864	BLOCK HEATER, ENGINE {Phillips} 120V/1500W	2/0	2
	Includes : BLOCK HEATER SOCKET Receptacle Type; Mounted below Drivers Door		
12WTA	FAN DRIVE SPECIAL EFFECTS Fan Cooling Ring with Fan Shroud Effects, Engine Mounted	0/0	0

<u>Code</u>	<u>Description</u>	<u>F/R Wt</u> (lbs)	<u>Tot Wt</u> (lbs)
12WBR	FAN OVERRIDE Manual; with Electric Switch on Instrument Panel, (Fan On with Switch On)	2/0	2
12WCX	HOSE CLAMPS, RADIATOR HOSES {Gates} Shrink Band Type	0/0	0
12WYZ	RADIATOR DRAIN & FILL FITTING SPECIAL; To Vacuum Out or Fill the Cooling System from the Bottom of Radiator, for Use with Quick-Connect Radiator Drain Tool or Shop Coolant Evacuation-Fill System	0/0	0
TRANSMISSION			
13GJS	TRANSMISSION, MANUAL {Fuller RTLO-18913A} 13-Speed Manual, Double Overdrive, Air Shift, Internal Lube Oil Pump	109/11	120
13WAS	CLUTCH HOUSING Aluminum; Available with 1350 to 2050 lb-ft Capacity Fuller Transmissions	-45/-8	-53
13WGJ	OIL COOLER, TRANSMISSION Water to Oil Type Included in Radiator End Tank (REQUIRES TRANSMISSION LUBE PUMP)	4/0	4
13XAA	PTO CONTROL, DASH MOUNTED For Customer Provided PTO; Includes Switch, Electric/Air Solenoid, Piping and Wiring	5/0	5
13WLX	TRANSMISSION OIL {EmGard 40W} Synthetic; 22 thru 33.99 Pints	0/0	0
CLUTCH			
11MRT	CLUTCH {Eaton Fuller Advantage} Self-Adjusting, 15.5" Dia Two-Plate, Cast Angle Spring, Ceramic, 7-Spring Coaxial VCT Plus Damper with Pre-Damper, 2"-10 Tooth Splines, Mechanical Pull Type Control, 6-Button Disc, 1860 lb-ft Torque Capacity	3/0	3
11WAJ	CLUTCH EFFECTS Hydraulic Clutch Actuation System	0/0	0
REAR AXLES, SUSPENSIONS			
14HRC	AXLE, REAR, TANDEM {Meritor RT-46-164EH} Single Reduction, Standard Width, 46,000-lb Capacity, Driver Controlled Locking Differential in Forward-Rear and Rear-Rear Axle, 200 Wheel Ends . Gear Ratio: 4.30 <u>Notes</u> : Axle Lead Time is 45 Days	0/487	487
14ULT	SUSPENSION, REAR, AIR, TANDEM {Hendrickson HAS-460-55} 46,000-lb Capacity, 55" Axle Spacing, 9.5" Ride Height, with Shock Absorbers, Mounted Inboard	0/87	87
14WMK	AXLE, REAR, LUBE {EmGard FE-75W-90} Synthetic Oil; 65 thru 89.99 Pints	0/0	0
14WZY	AXLE SHAFT MODIFICATION Axle Shaft Flanges Modified for 0.625" Diameter Drive Studs with Solid Type Cone-Locks	0/0	0
14862	PDL WARNING BUZZER Power Divider Lock	0/0	0
14899	SUSPENSION AIR CONTROL VALVE Pressure Release Control In Cab	0/1	1
FRONT AXLES			

<u>Code</u>	<u>Description</u>	<u>F/R Wt</u>	<u>Tot Wt</u>
		(lbs)	(lbs)
2ARZ	AXLE, FRONT NON-DRIVING {Meritor MFS-18-133A} Wide Track, I-Beam Type, 18,000-lb Capacity	126/0	126
FRONT SUSPENSIONS			
3ADG	SUSPENSION, FRONT, SPRING Parabolic Taper Leaf, Shackle Type, 18,000-lb Capacity, with Shock Absorbers	-49/0	-49
CABS, COWLS, BODIES			
16030	CAB Conventional, Day Cab Includes : CAB REAR SUSPENSION Air : CLEARANCE/MARKER LIGHTS (5) LED Roof Mounted : COAT HOOK, CAB Located on Rear Wall, Centered Above Rear Window : CONSOLE, CENTER Includes Two Cup Holders and One Additional Storage Area : CONSOLE, OVERHEAD Molded Plastic with Dual Storage Pockets, Retainer Nets and CB Radio Pocket; Located Above Driver and Passenger : COURTESY LIGHT (2) Driver and Passenger Door Mounted : DOME LIGHT, CAB Rectangular, Door and Instrument Panel Mounted Switch Activated, Timed Theater Dimming, Center Mounted, Integral to Console : FLOOR COVERING Rubber, Black : GLASS, ALL WINDOWS Tinted : GRAB HANDLE, CAB INTERIOR (1) "A" Pillar Mounted, Passenger Side : GRAB HANDLE, CAB INTERIOR (4) "B" Pillar and Door Mounted, Two Each Side : READING LIGHT, CAB Located in Overhead Console : STORAGE POCKET, DOOR (2) Full Length, Driver and Passenger Door	0/0	0
16ZHU	ACCESS, CAB AND FRAME Aluminum, Driver & Passenger Sides, Two Steps per Door; Left Side Frame Access Step, Includes One Deck Plate and Grab Handle, for use with Day Cab or Sleeper Cab	-48/-7	-55
16BAM	AIR CONDITIONER with Integral Heater and Defroster Includes : HOSE CLAMPS, HEATER HOSE Mubea Constant Tension Clamps	0/0	0
16VKK	CAB INTERIOR TRIM Diamond, for Day Cab	0/0	0
16XYW	CAB SOUND INSULATION Day Cab Interior Noise Reduction Package	0/0	0
16WLS	FRESH AIR FILTER Attached to Air Intake Cover on Cowl Tray in Front of Windshield Under Hood	0/0	0
16GEG	GAUGE CLUSTER Premium Level; English with English Electronic Speedometer Includes : GAUGE CLUSTER DISPLAY: Base Level (3" Monochromatic Display), Premium Level (5" LCD Color Display); Odometer, Voltmeter, Diagnostic Messages, Gear Indicator, Trip Odometer, Total Engine Hours, Trip Hours, MPG, Distance to Empty/Refill for : GAUGE CLUSTER Speedometer, Tachometer, Engine Coolant Temp, Fuel Gauge, DEF Gauge, Oil Pressure Gauge, Primary and Secondary Air Pressure	0/0	0

Code	Description	F/R	Wt (lbs)	Tot Wt (lbs)
	: WARNING SYSTEM Low Fuel, Low DEF, Low Oil Pressure, High Engine Coolant Temp, Low Battery Voltage (Visual and Audible), Low Air Pressure (Primary and Secondary)			
16HHE	GAUGE, AIR CLEANER RESTRICTION {Filter-Minder} Mounted in Instrument Panel	2/0		2
16HCS	GAUGE, TEMPERATURE, AMBIENT Sensor Wiring with Display Unit Mounted in Cluster	0/0		0
16SDC	GRAB HANDLE, EXTERIOR (2) Chrome, Towel Bar Type, with Anti-Slip Rubber Inserts, for Cab Entry Mounted Left and Right Side at B-Pillar	6/0		6
16GHU	GRAB HANDLE, CAB INTERIOR (2) Safety Yellow	0/0		0
16XJP	INSTRUMENT PANEL Wing Panel	0/0		0
16HKT	IP CLUSTER DISPLAY On Board Diagnostics Display of Fault Codes in Gauge Cluster	0/0		0
16SNT	MIRRORS (2) Aero Pedestal, Power Adjust, Heated, Turn Signals, Black Heads and Arms, 6.5" x 14" Flat Glass, Includes 6.5" x 6" Convex Mirrors, for 102" Load Width	0/0		0
	Notes : Mirror Dimensions are Rounded to the Nearest 0.5"			
16SNW	MIRROR, CONVEX, LOOK DOWN Right Side, Black, 6" x 10.5"	3/0		3
16SPA	MIRROR, CONVEX, HOOD MOUNTED (2) Right and Left Sides, Black, 7.5" x 7"	11/-1		10
16XRX	MODESTY PANEL Painted	0/0		0
16VLV	MONITOR, TIRE PRESSURE Omit	-10/-1		-11
16VCC	SEAT BELT All Orange; 1 to 3	0/0		0
16LWK	SEAT, DRIVER {ISRI} Series 300, Air Suspension, High Back, Vinyl, Single Chamber Lumbar, Inboard Armrest, Suspension Cover, Fore/Aft Isolator, Cushion Extension, Seat Tilt	0/0		0
16LUM	SEAT, PASSENGER {National} Non Suspension, High Back with Integral Headrest, Vinyl, with Fixed Back, with Under Seat Storage	29/11		40
16XWV	SUNSHADE, EXTERIOR Aerodynamic, Painted Roof Color, with Integral LED Clearance/Marker Lights	16/1		17
16WJU	WINDOW, POWER (2) and Power Door Locks, Left and Right Doors, Includes Express Down Feature	0/0		0
FRAMES				
1CGC	FRAME RAILS Heat Treated Alloy Steel (120,000 PSI Yield); 12.250" x 3.380" x 0.375" (304.8mm x 85.6mm x 9.5mm); 550.0" (13970mm) Maximum OAL	1/37		38
1LRB	BUMPER, FRONT Contoured, Steel, Painted, Heavy Duty, for HX	0/0		0
1AMR	CROSSMEMBER, FRAME TIE for Standard Duty	39/3		42
1832	DECK PLATE Aluminum, (2) Sections, 15" Wide	13/13		26
1616	FRAME RAILS WITH TAPERED REAR	0/-7		-7

<u>Code</u>	<u>Description</u>	<u>F/R Wt Tot Wt</u>	
		(lbs)	(lbs)
1WRW	TOW HOOK, FRONT (2) Frame Mounted; 80,000-lb. Total Capacity	15/0	15
1WXK	WHEELBASE RANGE 148" (375cm) Through and Including 189" (480cm)	-18/18	0
BRAKES			
4092	BRAKE SYSTEM, AIR Dual System for Tractor Applications <u>Includes</u> : BRAKE LINES Color and Size Coded Nylon : GLAD HANDS (2) One for Service and One for Emergency; Trailer Hoses from Cab : HAND CONTROL VALVE, AIR Mounted in Instrument Panel : PARKING BRAKE CONTROL Yellow and Red Knobs, Located on Instrument Panel : PARKING BRAKE VALVE Combination Valve for Tractor and Trailer : QUICK RELEASE VALVE On Rear Axle for Spring Brake Release: 1 for Forward Rear Axle : TRACTOR PROTECTION VALVE	19/-3	16
4AZY	AIR BRAKE ABS {Bendix AntiLock Brake System} 6-Channel (6 Sensor/ 6 Modulator) Electronic Stability Program, with Automatic Traction Control	0/0	0
4GBM	BRAKE, PARKING Manual Push-Pull Pneumatic Parking Brake	1/0	1
4XCR	BRAKES, FRONT {Meritor EX+H} Air Disc Type, Size 22.5", 23,000-lb Capacity	40/0	40
4XDX	BRAKE CHAMBERS, FRONT AXLE 20 SqIn, for Air Disc Brakes	1/0	1
4XDS	BRAKES, REAR {Meritor 16.5X8.625 Q-PLUS CAST} Air S-Cam Type, Cast Splder, Fabricated Shoe, Double Anchor Pin, Size 16.5" X 8.625", 23,000-lb Capacity per Axle	0/150	150
4EXU	BRAKE CHAMBERS, REAR AXLE {Bendix EverSure} 30/30 SqIn Spring Brake	0/14	14
4LGG	SLACK ADJUSTERS, REAR {Gunite} Automatic	0/28	28
4WDM	DUST SHIELDS, REAR BRAKE for Air Cam Brakes	0/20	20
4XEE	PARK BRAKE CHAMBERS, ADDITIONAL (2) Spring Brake Type	0/60	60
4SPA	AIR COMPRESSOR {Cummins} 18.7 CFM	0/0	0
4EDM	AIR DRYER {Bendix AD-HF} with Heater, Includes Pressure Protection Circuits, Safety Valve, Integral Purge Tank, Governor Pressure Settings 110 psi Cut-In/130 psi Cut-Out, Integrated PuraGuard Coalescing Filtration	0/0	0
4VKC	AIR DRYER LOCATION Mounted Inside Left Rail, Back of Cab	0/0	0
4VKK	AIR TANK LOCATION (2) Mounted Under Battery Box, Outside Right Rail, Back of Cab, Perpendicular to Rail	0/0	0
4WXR	DRAIN VALVE (2) {Berg} with Pull Chains, for Air Tanks	0/0	0
4808	HOSE TENDER Slide Bar with Single Spring Bracket, Bar Extended 4" from Cab	10/5	15

<u>Code</u>	<u>Description</u>	<u>F/R Wt</u> (lbs)	<u>Tot Wt</u> (lbs)
4XAM	TRAILER HOSES AND CABLES {Erich Jaeger} Straight, Phillips Rubber Hose, 14' Working Length, Aluminum Glad Hands with Rubber Seals, Lighting Cable with Polypropylene Composite Plug	8/4	12
STEERING			
SPTB	STEERING GEAR (2) {Sheppard M100/M80} Dual Power	110/-14	96
5710	STEERING COLUMN Tilting and Telescoping	0/0	0
5CAW	STEERING WHEEL 4-Spoke; 18" Dia., Black	0/0	0
DRIVELINES			
6DGU	DRIVELINE SYSTEM {Dana Spicer} SPL250 Main Driveline with SPL170 Interaxle Shaft, for 6x4	2/5	7
EXHAUST SYSTEMS			
7BLY	EXHAUST SYSTEM Horizontal Aftertreatment System, Frame Mounted Right Side Under Cab, for Single Vertical Tail Pipe, Cab Mounted Right Side	0/0	0
7BEU	AFTERTREATMENT COVER Aluminum	0/0	0
7SAP	ENGINE COMPRESSION BRAKE {Cummins} Interbrake For Cummins Signature/ISX/X15 Engines; Furnished with Engine	0/0	0
7WDM	EXHAUST HEIGHT 10'	0/0	0
7WDN	MUFFLER/TAIL PIPE GUARD (1) Aluminum	12/8	20
7WBA	TAIL PIPE (1) Turnback Type, Bright	-10/-3	-13
ELECTRICAL SYSTEMS			
8000	ELECTRICAL SYSTEM 12-Volt, Standard Equipment <u>Includes</u> : HAZARD SWITCH Push On/Push Off, Located on Instrument Panel to Right of Steering Wheel : HEADLIGHT DIMMER SWITCH Integral with Turn Signal Lever : PARKING LIGHT Integral with Front Turn Signal and Rear Tail Light : STARTER SWITCH Electric, Key Operated : STOP, TURN, TAIL & B/U LIGHTS Dual, Rear, Combination with Reflector : WINDSHIELD WIPER SWITCH 2-Speed with Wash and Intermittent Feature (5 Pre-Set Delays), Integral with Turn Signal Lever : WINDSHIELD WIPERS Single Motor, Electric, Cowl Mounted	0/0	0
8WXD	ALARM, PARKING BRAKE Electric Horn Sounds in Repetitive Manner When Vehicle Park Brake is "NOT" Set, with Ignition "OFF" and any Door Opened	0/0	0
8GXJ	ALTERNATOR {Leece-Neville AVI160P2013} Brush Type, 12 Volt, 160 Amp Capacity, Pad Mount	0/0	0
8RPP	ANTENNA Shark Fin, Roof Mounted	1/0	1
8THB	BACK-UP ALARM Electric, 102 dBA	0/3	3

Code	Description	F/R Wt Tot Wt	
		(lbs)	(lbs)
8VUK	BATTERY BOX Aluminum, with Plastic Cover, 18" Wide, 2-4 Battery Capacity, Mounted Right Side Back of Cab	0/0	0
8XNB	BATTERY DISCONNECT SWITCH 300 Amp, Disconnects Power to Power Distribution Center (PDC), Does Not Disconnect Charging Circuits, Locks with Padlock, Cab Mounted	7/1	8
8MSG	BATTERY SYSTEM {Fleetrite} Maintenance-Free, (3) 12-Volt 1980CCA Total, Top Threaded Stud	0/0	0
8RJW	CB RADIO Omit Power Feeds, Power Source and Wiring	0/0	0
8XAH	CIRCUIT BREAKERS Manual-Reset (Main Panel) SAE Type III with Trip Indicators, Replaces All Fuses	0/0	0
8WXB	HEADLIGHT WARNING BUZZER Sounds When Head Light Switch is on and Ignition Switch is in "Off" Position	0/0	0
8XNY	HEADLIGHTS Halogen	0/0	0
8836	HORN, AIR (2) Single Bell, Organ Tone, Extra Long, Chrome	4/0	4
8VAY	HORN, ELECTRIC Disc Style	0/0	0
8XPK	POWER SOURCE, ADDITIONAL Auxiliary Power Outlet (APO) with USB-A Port and USB-C Port, Located in the Instrument Panel	0/0	0
8RPS	RADIO AM/FM/WB/Clock/Bluetooth/USB Input/Auxiliary Input	3/0	3
8695	SNOW SHIELD (2) Chrome; for Dual Air Horns	1/0	1
8RMV	SPEAKERS (2) 6.5" Dual Cone Mounted in Doors	0/0	0
8WXG	STARTING MOTOR {Mitsubishi Electric Automotive America 105P} 12-Volt, with Soft-Start	0/0	0
8WEZ	TURN SIGNAL SWITCH Self-Canceling	0/0	0
FRONT END			
9ASE	FRONT END Tilting, Composite	0/0	0
9WAC	BUG SCREEN Mounted Behind Grille	5/0	5
9585	FENDER EXTENSIONS Rubber	18/0	18
9HCL	GRILLE Black Vertical Accent Bars, with Black Mesh	0/0	0
9AAB	LOGOS EXTERIOR Model Badges	0/0	0
9AAE	LOGOS EXTERIOR, ENGINE Badges	0/0	0
SPEEDOMETER, TOOLS, MISC			
10AGB	COMMUNICATIONS MODULE Telematics Device with Over the Air Programming; Includes Five Year Data Plan and International 360	0/0	0
10HJB	FIFTH WHEEL, AIR SLIDE {Fontaine SL7LWB725024} 24" Slide, Cast Top Plate, 7.25" Above Top of Frame, Left Hand Release	0/540	540
810000	FIFTH WHEEL LOCATION On Rear Axle Centerline	0/0	0
10WPR	MUD FLAP HOLDER Spring Loaded, Painted Black, with Red and White Reflective Tape, Less Flaps	-7/29	22

Code	Description	F/R Wt Tot Wt	
		(lbs)	(lbs)
10WSX	MUD FLAPS, REAR Black Poly, with International Logo, Less Holders	-3/14	11
10060	PAINT SCHEMATIC, PT-1 Single Color, Design 100	0/0	0
10761	PAINT TYPE Base Coat/Clear Coat, 1-2 Tone	0/0	0
10SLV	PROMOTIONAL PACKAGE Government Silver Package	0/0	0
10WCY	SAFETY TRIANGLES	5/1	6
FUEL TANKS			
15SJR	FUEL TANK Top Draw, Non-Polished Aluminum, 26" Dia, 100 US Gal (379L), Mounted Left Side, Under Cab	19/30	49
15WEY	DEF TANK 10.8 US Gal (41L) Capacity, Frame Mounted Outside Left Rail, Under Cab	0/0	0
15LNA	FUEL HEATER PLUMBING {Cummins} Plumbing for Thermal Recirculation Valve (TRV) Mounted to Cummins X15 Engines, Thermostatically Controlled	0/0	0
15LPU	FUEL/WATER SEPARATOR {Racor 6600} Pre-Filter and Filter Base, Includes Water-in-Fuel Sensor	-3/0	-3
WHEELS, TIRES - FRONT			
27DHK	WHEELS, FRONT DISC; 22.5x12.25 Rims, Non-Polished Aluminum, 10-Stud, 285.75mm BC, Hub-Piloted, Flanged Nut, with Steel Hubs	0/0	0
7792655441	(2) TIRE, FRONT 385/65R22.5 Load Range L HAC 3 (CONTINENTAL), 479 rev/mile, 68 MPH, All-Position	78/0	78
WHEELS, TIRES - REAR			
28DJM	WHEELS, REAR {Maxion 91541} DUAL DISC; 22.5x8.25 Rims, Painted Steel, 2-Hand Hole, 10-Stud, 285.75mm BC, Hub-Piloted, Flanged Nut, with Steel Hubs	0/-8	-8
7382135444	(8) TIRE, REAR 11R22.5 Load Range H HDR2+ (CONTINENTAL), 491 rev/mile, 75 MPH, Drive	0/40	40
WHEELS MISC OPTIONS			
29PAS	PAINT IDENTITY, REAR WHEELS Disc Rear Wheels; with Vendor Applied White Powder Coat Paint	0/0	0
29WLK	WHEEL BEARING, FRONT, LUBE {EmGard FE-75W-90} Synthetic Oil	0/0	0
BODY INTEGRATION			
60AAG	BDY INTG, REMOTE POWER MODULE Mounted Inside Cab Behind Driver Seat, Up to 6 Outputs & 6 Inputs, Max 20 amp per Channel, Max 80 amp Total; Includes 1 Switch Pack with Latched Switches Cab schematic 100LZ Location 1: 2303, Red (Std) Chassis schematic N/A	0/0	0

<u>Code</u>	<u>Description</u>	<u>F/R Wt</u>	<u>Tot Wt</u>
		(lbs)	(lbs)
Services Section:			
WARRANTY			
40132	WARRANTY Standard for HX520, HX620, Effective with Vehicles Built January 1, 2021 or Later, CTS-2015B	0/0	0
	Total Component Weight:	10482/8293	18775
		(lbs)	(lbs)
1	Install (2) Protech Aluminum diamond plate 1/2 fenders over front drive with Stainless mounting hardware, Install rear poly extension over tandem axle with support arms as needed	0/0	0
2	Install Tractor Wet Chelsea 489 Hotshift PTO 3.94 CID Permco gear pump directly couple to the PTO DVA 3 way valve section with on/off 12v coil for lowboy trailer Use chassis switch to activate valve section Hyd tank installed on side of frame Ball valve shutoff on tanks In-Line return filter AW32 hydraulic oil (2) 3/4" 9' jumper hoses with couplers 2 sets od SS couplers for truck side and new set for trailer side shipped loose with truck Hyd. lines labeled for pressure and return Pogo stick for HYD lines Rear Lowboy arm plate 3/4" on rear frame	0/0	0
	Total Body Allied:	0/0	0
		(lbs)	(lbs)
	MI Deal Fee Spec 3958-0178D	0/0	0
	Total Goods Purchased:	0/0	0

The weight calculations included in this proposal are an estimate of future vehicle weight. The actual weight as manufactured may be different from the estimated weight. Navistar, Inc. shall not be liable for any consequences resulting from any differences between the estimated weight of a vehicle and the actual weight.

(0012EWZ)

ATTACHMENTS: 0012WBR 0012THT 0007SAP 0016030

<u>Parameter</u>	<u>Value</u>	<u>UOM</u>
Max Accelerator Vehicle Speed	68	MPH
Road Speed Governor Upper Droop	0	MPH
Road Speed Governor Lower Droop	3.0	MPH
Driver Initiated Override (DIO)	N, DISABLE FEATURE OR FUNCTION	N/A
DIO Maximum Road Speed Delta	3	MPH
DIO Maximum Distance	30	MILES
Max Engine Speed No Veh Speed Sensr	1721	RPM
Road Speed Governor Type	1, TRADITIONAL	N/A
Fuel Economy Adjustment Factor	0, BALANCED FUEL ECONOMY	N/A
Gear Down Protection Enable	Y, ENABLE FEATURE OR FUNCTION	N/A
GDP - Heavy Load Vehicle Speed	62	MPH
GDP - Light Load Vehicle Speed	57	MPH
Driver Reward Enable	N, DISABLE FEATURE OR FUNCTION	N/A
Driver Reward Mode	2, ROAD SPEED GOVERNOR & CRUISE CONTROL	N/A
Fuel Economy - Expected Level	7.00	MPG
Fuel Economy - Good Level	7.25	MPG
Fuel Economy - Best Level	7.50	MPG
% Idle Time - Expected Level	20	%
% Idle Time - Good Level	15	%
% Idle Time - Best Level	10	%
Speed Reward - Expected Level	0	MPH
Speed Reward - Good Level	0	MPH
Speed Reward - Best Level	0	MPH
Speed Reward - Penalty Level	0	MPH
Idle Speed Adjustment Enable	N, DISABLE FEATURE OR FUNCTION	N/A
Low Idle Speed	600	RPM
Idle Shutdown Enable	Y, ENABLE FEATURE OR FUNCTION	N/A
ISD Time Before Shutdown	5.0	MIN
ISD Percent Engine Loading	50	%
ISD In PTO	N, DISABLE FEATURE OR FUNCTION	N/A
ISD Manual Override	N, DISABLE FEATURE OR FUNCTION	N/A
ISD With Parking Brake Set	N, DISABLE FEATURE OR FUNCTION	N/A
ISD Ambient Temperature Override	N, DISABLE FEATURE OR FUNCTION	N/A
ISD Cold Ambient Air Temperature	30	F
ISD Intermediate Ambient Air Temp	40	F
ISD Hot Ambient Air Temperature	81	F
ISD Manual Override Inhibit Zone En	N, DISABLE FEATURE OR FUNCTION	N/A
ISD Hot Ambient Automatic Override	Y, ENABLE FEATURE OR FUNCTION	N/A
ISD Engine Coolant Temp Threshold	53	F
Cruise Control Enable	Y, ENABLE FEATURE OR FUNCTION	N/A
CC Maximum Vehicle Speed	68	MPH
CC Save Set Speed	N, DISABLE FEATURE OR FUNCTION	N/A
CC Upper Droop	0.0	MPH
CC Lower Droop	3.0	MPH
CC Auto Resume	N, DISABLE FEATURE OR FUNCTION	N/A
CC Ovrspd Retard Activation Enable	Y, ENABLE FEATURE OR FUNCTION	N/A
CC Overspeed for Max Retarder	5.0	MPH
CC Overspeed for Min Retarder	3.0	MPH
CC Engine Brake Swtch Bypass Enable	N, DISABLE FEATURE OR FUNCTION	N/A
Retarder - Min Vehicle Speed	2	MPH
Retarder - Delay Time	1.0	SEC
Retarder - Service Brake Activation	Y, ENABLE FEATURE OR FUNCTION	N/A
Force Fan On With Retarder	N, DISABLE FEATURE OR FUNCTION	N/A
Engine Fan Min On Time For AC	30	SEC
Remote Accelerator Enable	N, DISABLE FEATURE OR FUNCTION	N/A

Remote Accelerator Mode	1, REMOTE ACCELERATOR PEDAL OR LEVER WITH TRANS VERIFICATION	N/A
PTO Enable	N, DISABLE FEATURE OR FUNCTION	N/A
PTO In Cab Mode	Y, ENABLE FEATURE OR FUNCTION	N/A
Remote PTO Enable	N, DISABLE FEATURE OR FUNCTION	N/A
Remote Station PTO Enable	N, DISABLE FEATURE OR FUNCTION	N/A
PTO Max Engine Speed	2000	RPM
PTO Min Engine Speed	600	RPM
PTO Maximum Engine Load	800	LB-FT
PTO Max Vehicle Speed	2	MPH
PTO Accelerator Override	N, DISABLE FEATURE OR FUNCTION	N/A
PTO Accel Override Max Engine Speed	2030	RPM
PTO Clutch Override	N, DISABLE FEATURE OR FUNCTION	N/A
PTO Service Brake Override	Y, ENABLE FEATURE OR FUNCTION	N/A
PTO Parking Brake Interlock Mode	3, PTO PRK BRK INT TYPE SET TO ALL	N/A
PTO Transmission Neutral Interlock	N, DISABLE FEATURE OR FUNCTION	N/A
PTO Eng Spd Limit w/VSS Limit	N, DISABLE FEATURE OR FUNCTION	N/A
PTO Ignore Vehicle Speed Sensor	N, DISABLE FEATURE OR FUNCTION	N/A
PTO Resume Switch Speed	925	RPM
PTO Set Switch Speed	850	RPM
PTO Additional Switch Speed	1000	RPM
PTO Ramp Rate	100	RPM/SEC
Remote PTO Number of Speed Settings	1	N/A
Remote PTO Speed Setting 1	600	RPM
Remote PTO Speed Setting 2	600	RPM
Remote PTO Speed Setting 3	600	RPM
Remote PTO Speed Setting 4	600	RPM
Remote PTO Speed Setting 5	600	RPM
Remote Station PTO Resume Sw Spd	750	RPM
Remote Station PTO Set Switch Speed	600	RPM
Remote Station PTO Addition Sw Spd	800	RPM
Transmission Driven PTO	N, DISABLE FEATURE OR FUNCTION	N/A
Transmission Driven PTO Type	2, TRANSMISSION DRIVEN IRREGULAR LOAD	N/A
DPF Active Regen in PTO Mode	N, DISABLE FEATURE OR FUNCTION	N/A
Powertrain Protection Enable	N, DISABLE FEATURE OR FUNCTION	N/A
Max Torque Allow By Axle/Driveshaft	32744	LB-FT
Max Torque in Top Gear Range	5000	LB-FT
Max Torque in Int. Gear Range	5000	LB-FT
Max Torque in Low Gear Range	5000	LB-FT
Max Torque w/o Vehicle Speed	5000	LB-FT
Lowest Gear of Top Gear Range	2.00	N/A
Lowest Gear of Int. Gear Range	10.00	N/A
Lowest Gear of Low Gear Range	16.00	N/A
Engine Protection Shutdown	Y, ENABLE FEATURE OR FUNCTION	N/A
Engine Protection Restart Inhibit	Y, ENABLE FEATURE OR FUNCTION	N/A
Engine Prot Coolant Level Shutdown	N, DISABLE FEATURE OR FUNCTION	N/A
Sudden Veh Speed Decel Threshold	6.96	MPH
Trip Information Vehicle Ovrsped1	75	MPH
Trip Information Vehicle Ovrsped2	77	MPH
Veh Speed Sensor Anti Tamper Level	1, HIGH LEVEL	N/A
Master Password	000000	N/A
Adjustment Password	000000	N/A
Reset Password	000000	N/A

These Electronic Parameters have not been finalized

(US DOLLAR)

<u>Description</u>	<u>Price</u>
Total Factory List Price Including Options:	\$290,842.00
Total Goods Purchased:	\$1,341.12
Total Preparation And Delivery:	\$1,760.00
Total Freight:	\$3,100.00
Total Factory List Price Including Freight:	\$297,043.12
Less Customer Allowance:	(\$157,817.20)
Total Vehicle Price:	\$139,225.92
Total Body/Allied Equipment:	\$11,838.00
Total Sale Price:	\$151,063.92
Total Per Vehicle Sales Price:	\$151,063.92
Total Net Sales Excluding Taxes:	\$151,063.92
Total License, Title:	\$15.00
Net Sales Price:	\$151,078.92

Note Additional Surcharges may be added by the Manufacturer

Payment for the chassis is due upon delivery of the cab/chassis to the end user or body company; which ever occurs first. If payment is not received in a timely manner additional floorplan(interest) costs may be charged to the end-user customer.

Please make all purchase orders and checks payable to:

Tri-County International Trucks, Inc.
5701 Wyoming Ave.
Dearborn, MI 48126

Please review this proposal very carefully. Your signature below indicates that you accept the specifications and payment terms, contained herein as written and that you are able to approve said specifications for order and payment terms. Please include this proposal number on all correspondence and purchase orders.

Approved by Seller:

Official Title and Date

Authorized Signature

TRI COUNTY INTL TRUCKS
3001 E HIGH ST
JACKSON MI 49203
(517)783-2721

This proposal is not binding upon the seller without Seller's Authorized Signature

Accepted by Purchaser:

City of Flint

Firm or Business Name

Clyde D. Edwards, Feb 26, 2025 14:34 EST

Authorized Signature and Date

City Administrator 02/26/25

Official Title and Date

The TOPS FET calculation is an estimate for reference purposes only. The seller or retailer is responsible for calculating and reporting/paying appropriate FET to the IRS.

The limited warranties applicable to the vehicles described herein are Navistar, Inc.'s standard printed warranties which are incorporated herein by reference and to which you have been provided a copy and hereby agree to their terms and conditions.

ORDINANCE NO. _____

An Ordinance to amend the Flint City Code of Ordinances by amending Chapter 24, Housing.

IT IS HEREBY ORDAINED BY THE PEOPLE OF THE CITY OF FLINT:

Sec. 1. An Ordinance to amend the Flint City Code of Ordinances by amending Chapter 24, Housing, by adding Article IV. Fair Chance Access to Rental Housing, Sections 24-114 to 24-127, which shall read in its entirety as follows:

§24-114 PURPOSE.

THE PURPOSE OF THIS ARTICLE IS TO ENHANCE THE HEALTH, SAFETY AND GENERAL WELFARE OF THE PUBLIC BY ENSURING CITIZENS WITH ARREST AND CONVICTION RECORDS HAVE A FAIR OPPORTUNITY TO SECURE HOUSING BY REGULATING THE USE OF CRIMINAL BACKGROUND CHECKS AS PART OF THE TENANT SCREENING PROCESS, THEREBY FACILITATING RE-INTEGRATION INTO SOCIETY, REDUCING RECIDIVISM AND ITS ASSOCIATED CRIMINAL JUSTICE AND SOCIETAL COSTS. BARRIERS TO OPPORTUNITIES FOR PEOPLE WITH ARREST OR CONVICTION RECORDS INCREASE RECIDIVISM AND JEOPARDIZE THE SAFETY OF THE PUBLIC, DISRUPT THE FINANCIAL AND OVERALL STABILITY OF AFFECTED FAMILIES AND COMMUNITIES, AND IMPEDE THE CITY FROM ACHIEVING ITS MAXIMUM POTENTIAL OF ECONOMIC GROWTH.

§24-115 SCOPE.

- (A) THIS ARTICLE DOES NOT INTEND, AND SHALL NOT BE CONSTRUED, TO REQUIRE A HOUSING PROVIDER TO GIVE PREFERENCE TO ANYONE OR TO RENT TO AN UNQUALIFIED TENANT WITH AN ARREST OR CONVICTION RECORD. MOREOVER, THIS ARTICLE SHALL NOT BE CONSTRUED TO LIMIT A HOUSING PROVIDER'S ABILITY TO CHOOSE THE MOST QUALIFIED AND APPROPRIATE CANDIDATE FROM APPLICANTS FOR HOUSING.**

- (B) THIS ARTICLE DOES NOT INTEND, AND SHALL NOT BE CONSTRUED, TO CREATE OR IMPOSE A DUTY, OR TO CREATE A PRIVATE CAUSE OF ACTION AGAINST THE CITY, ITS ELECTED OFFICIALS, APPOINTEES, OFFICERS, AGENTS, OR EMPLOYEES.**

§24-116 DEFINITIONS.

FOR THE PURPOSES OF THIS ARTICLE, THE FOLLOWING WORDS AND PHRASES SHALL HAVE THE MEANING RESPECTIVELY ASCRIBED TO THEM BY THIS SECTION:

ADMINISTERING AGENCY MEANS THE OFFICE OF THE OMBUDSPERSON.

ADVERSE ACTION MEANS TO EVICT AN INDIVIDUAL, FAIL OR REFUSE TO RENT OR LEASE REAL PROPERTY TO AN INDIVIDUAL, FAIL OR REFUSE TO CONTINUE TO RENT OR LEASE REAL PROPERTY TO AN INDIVIDUAL, FAIL OR REFUSE TO ADD A HOUSEHOLD MEMBER TO AN EXISTING LEASE, OR TO REDUCE ANY TENANT SUBSIDY. THE ADVERSE ACTION MUST RELATE TO REAL PROPERTY LOCATED IN THE CITY OF FLINT.

APPLICANT MEANS AN INDIVIDUAL APPLYING TO RENT OR LEASE ELIGIBLE HOUSING. IT ALSO INCLUDES AN INDIVIDUAL APPLYING TO BE ADDED TO AN EXISTING LEASE FOR ELIGIBLE HOUSING.

ARREST MEANS A RECORD FROM ANY JURISDICTION THAT DOES NOT RESULT IN A CONVICTION AND INCLUDES INFORMATION INDICATING THAT A PERSON HAS BEEN QUESTIONED, APPREHENDED, TAKEN INTO CUSTODY OR DETAINED, OR HELD FOR INVESTIGATION BY A LAW ENFORCEMENT, POLICE OR A PROSECUTORIAL AGENCY, OR CHARGED WITH, INDICTED, OR TRIED AND ACQUITTED FOR ANY FELONY, MISDEMEANOR, OR OTHER CRIMINAL OFFENSE. ARREST IS A TERM THAT IS SEPARATE AND DISTINCT FROM, AND THAT DOES NOT INCLUDE, UNRESOLVED ARREST AS DEFINED IN THIS SECTION.

BACKGROUND CHECK REPORT MEANS ANY CRIMINAL HISTORY REPORT ACCESSIBLE THROUGH THE MICHIGAN STATE POLICE INTERNET CRIMINAL HISTORY ACCESS TOOL (I-CHAT), COURTS, OR BY ANY CONSUMER REPORTING, OR TENANT SCREENING, AGENCY OR BUSINESS.

CONVICTION MEANS A RECORD FROM ANY JURISDICTION, WHICH INCLUDES INFORMATION INDICATING THAT A PERSON HAS BEEN CONVICTED OF A FELONY OR MISDEMEANOR, PROVIDED, THAT THE CONVICTION IS ONE FOR WHICH THE PERSON HAS BEEN PLACED ON PROBATION, FINED, IMPRISONED OR PAROLED. THOSE MATTERS IDENTIFIED IN SECTION 24-118, WHICH A HOUSING PROVIDER MAY NOT MAKE AN INQUIRY AND WHICH THEY MAY NOT BASE AN ADVERSE ACTION, ARE NOT CONSIDERED CONVICTIONS FOR PURPOSES OF THIS ARTICLE.

CONVICTION HISTORY MEANS INFORMATION REGARDING ONE OR MORE CONVICTIONS OR UNRESOLVED ARRESTS, TRANSMITTED ORALLY OR IN WRITING OR BY ANY OTHER MEANS, AND OBTAINED FROM ANY SOURCE, INCLUDING, BUT NOT LIMITED TO, THE INDIVIDUAL TO WHOM THE INFORMATION PERTAINS OR A BACKGROUND CHECK REPORT.

DIRECTLY RELATED CONVICTION MEANS THAT THE CONDUCT FOR WHICH THE PERSON WAS CONVICTED OR THAT IS THE SUBJECT OF AN UNRESOLVED ARREST THAT HAS A DIRECT AND SPECIFIC NEGATIVE BEARING ON THE HEALTH, SAFETY, OR RIGHT TO PEACEFUL ENJOYMENT OF THE PREMISES BY PERSONS AND INCLUDES ONE OR MORE OF THE OFFENSES LISTED IN SECTION 24-119(B) OF THIS CODE. IN DETERMINING WHETHER THE

CONVICTION OR UNRESOLVED ARREST IS DIRECTLY RELATED TO THE HOUSING, THE HOUSING PROVIDER SHALL CONSIDER WHETHER THE HOUSING OFFERS THE OPPORTUNITY FOR THE SAME OR SIMILAR OFFENSE TO OCCUR, WHETHER CIRCUMSTANCES LEADING TO THE CONDUCT FOR WHICH THE PERSON WAS CONVICTED WILL RECUR IN THE HOUSING, AND WHETHER SUPPORTIVE SERVICES THAT MIGHT REDUCE THE LIKELIHOOD OF A RECURRENCE OF SUCH CONDUCT ARE AVAILABLE ON-SITE. THOSE MATTERS IDENTIFIED IN SECTION 24-118(A)(2) OF THIS CODE, WHICH A HOUSING PROVIDER MAY NOT MAKE AN INQUIRY AND WHICH THEY MAY NOT BASE AN ADVERSE ACTION, MAY NOT QUALIFY AS A DIRECTLY RELATED CONVICTIONS.

DWELLING OR DWELLING UNIT MEANS A SINGLE UNIT PROVIDING COMPLETE, INDEPENDENT LIVING FACILITIES OCCUPIED, OR INTENDED TO BE OCCUPIED, IN WHOLE OR IN PART BY ONE OR MORE PERSONS, INCLUDING PERMANENT SPACE AND PROVISIONS FOR LIVING, COOKING, EATING, SANITATION, AND SLEEPING.

ELIGIBLE HOUSING MEANS ANY RENTAL PROPERTY IN THE CITY OF FLINT AVAILABLE FOR RENT OR LEASE WHERE A SINGLE STRUCTURE CONTAINS MORE THAN FOUR DWELLING UNITS OR MORE THAN FOUR RENTAL PROPERTIES ARE OWNED BY THE SAME PERSON.

ENFORCING AGENCY MEANS THE POLICE DEPARTMENT.

EVIDENCE OF REHABILITATION OR OTHER MITIGATING FACTORS MEANS, BUT SHALL NOT BE LIMITED TO, A PERSON'S SATISFACTORY COMPLIANCE WITH ALL TERMS AND CONDITIONS OF PAROLE OR PROBATION, EXCEPT INABILITY TO PAY FINES, FEES, AND RESTITUTION DUE TO INDIGENCE SHALL NOT BE CONSIDERED NONCOMPLIANCE WITH TERMS AND CONDITIONS OF PAROLE OR PROBATION OR BOTH; EMPLOYER RECOMMENDATIONS, ESPECIALLY CONCERNING A PERSON'S POST-CONVICTION EMPLOYMENT; EDUCATIONAL ATTAINMENT OR VOCATIONAL OR PROFESSIONAL TRAINING SINCE THE CONVICTION, INCLUDING TRAINING RECEIVED WHILE INCARCERATED; COMPLETION OR ACTIVE PARTICIPATION IN REHABILITATIVE TREATMENT, FOR EXAMPLE, ALCOHOL OR DRUG TREATMENT; LETTERS OF RECOMMENDATION FROM COMMUNITY ORGANIZATIONS, COUNSELORS OR CASE MANAGERS, TEACHERS, COMMUNITY LEADERS OR PROBATION OR PAROLE OFFICERS WHO HAVE OBSERVED THE APPLICANT SINCE HIS OR HER CONVICTION(S); AND THE AGE OF THE PERSON AT THE TIME OF THE CONVICTION. SUCCESSFUL COMPLETION OF PAROLE, PROBATION, MANDATORY SUPERVISION, OR POST-RELEASE COMMUNITY SUPERVISION SHALL CREATE A PRESUMPTION OF REHABILITATION. EXAMPLES OF MITIGATING FACTORS THAT ARE OFFERED VOLUNTARILY BY THE PERSON MAY INCLUDE, BUT ARE NOT LIMITED TO, EXPLANATION OF THE PRECEDENT COERCIVE CONDITIONS, INTIMATE PHYSICAL OR EMOTIONAL ABUSE, OR UNTREATED SUBSTANCE ABUSE OR MENTAL ILLNESS THAT CONTRIBUTED TO THE CONVICTION.

HOUSING PROVIDER MEANS ANY ENTITY THAT OWNS, MASTER LEASES, MANAGES, OR RENTS ELIGIBLE HOUSING IN THE CITY OF FLINT. ANY AGENT, SUCH AS A PROPERTY MANAGEMENT COMPANY, WHICH MAKES TENANCY DECISIONS ON BEHALF OF THE AFOREMENTIONED ENTITIES, SHALL ALSO BE CONSIDERED A HOUSING PROVIDER.

INQUIRE MEANS ANY DIRECT OR INDIRECT CONDUCT INTENDED TO GATHER INFORMATION FROM OR ABOUT AN APPLICANT, OR A POTENTIAL APPLICANT OR CANDIDATE, USING ANY MODE OF COMMUNICATION, INCLUDING, BUT NOT LIMITED TO, APPLICATION FORMS, INTERVIEWS, AND BACKGROUND CHECK REPORTS.

PERSON MEANS ANY INDIVIDUAL, PARTNERSHIP, FIRM, COMPANY, CORPORATION, ASSOCIATION, SOLE PROPRIETORSHIP, LIMITED-LIABILITY COMPANY, JOINT VENTURE, ESTATE, TRUST, OR ANY OTHER LEGAL ENTITY.

RENTAL PROPERTY MEANS A NON-OWNER OCCUPIED DWELLING UNIT OR UNITS THAT:

- (1) IS OR ARE LET, OR OCCUPIED, BY PERSONS, INCLUDING A FAMILY MEMBER OF THE OWNER, PURSUANT TO AN ORAL OR WRITTEN RENTAL CONTRACT, OR LEASE, OR OTHER ORAL OR WRITTEN AGREEMENT OR UNDERSTANDING FOR OCCUPATION, WITH OR WITHOUT, MONETARY COMPENSATION; OR
- (2) WILL BE OFFERED FOR OCCUPANCY UNDER AN ORAL OR WRITTEN RENTAL CONTRACT OR LEASE, OR OTHER ORAL OR WRITTEN AGREEMENT OR UNDERSTANDING FOR OCCUPATION, WITH OR WITHOUT, MONETARY COMPENSATION TO ANY PERSON; OR
- (3) IS OR ARE CONTAINED WITHIN A BUILDING WITH TWO OR MORE DWELLING UNITS THAT ARE NOT OCCUPIED BY THE OWNER; OR
- (4) HAS OR HAVE BEEN ADVERTISED TO THE PUBLIC OR PREVIOUSLY REGISTERED WITH THE CITY AS RENTAL PROPERTY.

UNRESOLVED ARREST MEANS AN ARREST THAT IS UNDERGOING AN ACTIVE PENDING CRIMINAL INVESTIGATION OR TRIAL THAT HAS NOT YET BEEN RESOLVED. AN ARREST HAS BEEN RESOLVED IF THE ARRESTEE WAS RELEASED AND NO ACCUSATORY PLEADING WAS FILED CHARGING HIM OR HER WITH AN OFFENSE, OR IF THE CHARGES HAVE BEEN DISMISSED OR DISCHARGED BY THE PROSECUTING ATTORNEY OR THE COURT.

§24-117 APPLICABILITY; ELIGIBLE HOUSING.

THIS ARTICLE SHALL APPLY TO ALL HOUSING PROVIDERS WITH ELIGIBLE HOUSING AS DEFINED IN THIS ARTICLE AVAILABLE FOR RENT OR LEASE LOCATED IN THE CITY OF FLINT.

§24-118 PROHIBITION ON HOUSING PROVIDER INQUIRING INTO CRIMINAL CONVICTIONS OF APPLICANTS AND THEIR HOUSEHOLD MEMBERS UNTIL BEING INTERVIEWED OR QUALIFIED; BASIS FOR ADVERSE ACTION.

(A) EXCEPT AS PROVIDED IN SECTION 24-119 OF THIS CODE, HOUSING PROVIDERS SHALL NOT:

(1) INQUIRE ABOUT OR REQUIRE APPLICANTS TO DISCLOSE CONVICTION HISTORY AS PART OF TENANT SCREENING PROCESS UNTIL THE HOUSING PROVIDER:

A. HAS DETERMINED THE APPLICANT IS QUALIFIED TO RENT THE HOUSING UNIT UNDER ALL OF THE HOUSING PROVIDER'S CRITERIA NOT RELATED TO POTENTIAL PAST CRIMINAL CONVICTIONS OR AN UNRESOLVED ARREST; AND

B. HAS PROVIDED TO THE APPLICANT A CONDITIONAL LEASE AGREEMENT THAT COMMITS THE UNIT TO THE APPLICANT AS LONG AS THE APPLICANT PASSES THE CONVICTION HISTORY REVIEW.

(2) BASE AN ADVERSE ACTION IN WHOLE OR IN PART:

A. ON AN UNRESOLVED ARREST OR AN ARREST NOT LEADING TO A CONVICTION;

B. ON PARTICIPATION IN OR COMPLETION OF A DIVERSION OR A DEFERRAL OF JUDGMENT PROGRAM;

C. ON A CONVICTION THAT HAS BEEN JUDICIALLY DISMISSED, EXPUNGED, VOIDED, INVALIDATED OR OTHERWISE RENDERED INOPERATIVE BY A COURT OF LAW OR BY EXECUTIVE PARDON.

D. ON A CONVICTION OR ANY OTHER DETERMINATION OR ADJUDICATION IN THE JUVENILE JUSTICE SYSTEM, OR INFORMATION REGARDING A MATTER CONSIDERED IN OR PROCESSED THROUGH THE JUVENILE JUSTICE SYSTEM;

E. ON A MISDEMEANOR CONVICTION THAT IS MORE THAN FIVE THREE YEARS OLD, CALCULATED FROM THE DATE OF SENTENCING; OR

F. ON INFORMATION PERTAINING TO AN OFFENSE OR VIOLATION OTHER THAN A FELONY OR MISDEMEANOR, SUCH AS A CIVIL INFRACTION.

(3) A HOUSING PROVIDER SHALL NOT INCLUDE QUESTIONS REGARDING OR REQUIRE APPLICANTS TO DISCLOSE ON ANY HOUSING APPLICATION THE FACTS OR DETAILS OF ANY CONVICTION HISTORY OR ANY MATTER IDENTIFIED IN SUBSECTION (2) OF THIS SECTION.

(B) IT IS THE RESPONSIBILITY OF A HOUSING PROVIDER TO ENSURE THAT ITS EMPLOYEES AND AGENTS COMPLY WITH THIS ARTICLE.

§24-119 EXCEPTIONS TO PROHIBITION.

(A) THIS ARTICLE DOES NOT LIMIT THE RIGHT OF A HOUSING PROVIDER TO TAKE ANY OF THE FOLLOWING ACTIONS:

(1) CONDUCT CONVICTION HISTORY OR OBTAIN BACKGROUND CHECK REPORTS ON APPLICANTS WHERE THERE IS A STATUTORY DUTY TO DO SO; OR

(2) NOTIFY APPLICANTS THAT APPLICABLE LAWS, INCLUDING THOSE SET FORTH IN SUBSECTION (B) OF THIS SECTION WILL DISQUALIFY AN INDIVIDUAL WITH A PARTICULAR CONVICTION HISTORY FROM ELIGIBILITY FOR TENANCY.

(B) REGARDING APPLICANTS AND THEIR HOUSEHOLD MEMBERS, A HOUSING PROVIDER MAY BASE AN ADVERSE ACTION IN WHOLE OR IN PART ON DIRECTLY RELATED CONVICTIONS THAT INCLUDES ONE OR MORE OF THE FOLLOWING:

(1) ANY CONVICTION WHERE STATE OR FEDERAL LAW PROHIBITS THE APPLICANT FROM BEING ELIGIBLE FOR PUBLIC HOUSING; OR

(2) ANY CONVICTION UNDER MCL. 750.520B (CRIMINAL SEXUAL CONDUCT IN THE FIRST DEGREE), 750.520C (CRIMINAL SEXUAL CONDUCT IN THE SECOND DEGREE), 750.520D (CRIMINAL SEXUAL CONDUCT IN THE THIRD DEGREE), 750.520E (CRIMINAL SEXUAL CONDUCT IN THE FOURTH DEGREE), OR THAT OTHERWISE LEADS TO THE APPLICANT BECOMING A LIFETIME REGISTERED SEX OFFENDER; OR

(3) ANY CONVICTION FOR VIOLENT OR DRUG-RELATED FELONIES; OR

(4) CONVICTION FOR FELONIES COMMITTED WITHIN THE LAST ~~TEN~~ THREE YEARS OR IMPRISONMENT FOR FELONIES WITHIN THE LAST FIVE THREE YEARS; OR

(5) ANY CONVICTION FOR CRIMES AGAINST LANDLORDS, MANAGEMENT AGENTS, THEIR EMPLOYEES OR AGENTS, OR OTHER TENANTS OR REAL PROPERTY; OR

(6) ANY CONVICTION OR PLEA TO ANY CRIME INVOLVING ARSON; OR

(7) ANY CONVICTION OR PLEA TO ANY CRIME INVOLVING METAL THEFT, VANDALIZING, OR OTHERWISE DAMAGING REAL PROPERTY.

§24-120 PROCEDURES FOR USE OF EVIDENCE OF REHABILITATION OR OTHER MITIGATING FACTORS IN HOUSING DECISIONS; REQUIREMENT FOR INDIVIDUALIZED ASSESSMENT.

(A) CONSISTENT WITH THE PROCEDURES IN THIS SECTION AND SUBJECT TO STATE AND FEDERAL LAW, A HOUSING PROVIDER SHALL OFFER THE APPLICANT A REASONABLE OPPORTUNITY TO PRESENT EVIDENCE OF REHABILITATION OR OTHER MITIGATING FACTORS RELATED TO CONVICTIONS WITHIN THE PREVIOUS ~~FIVE~~ THREE YEARS.

(B) IN REVIEWING AN APPLICANT'S CRIMINAL HISTORY AND MAKING A DECISION RELATED TO ELIGIBLE HOUSING BASED ON SUCH HISTORY, A HOUSING PROVIDER SHALL CONDUCT AN INDIVIDUALIZED ASSESSMENT, CONSIDERING ONLY:

(1) CONVICTIONS THAT WARRANT DENIAL BASED ON LOCAL, STATE, OR FEDERAL LAW; AND

(2) TIME THAT HAS ELAPSED SINCE THE CONVICTION; AND

(3) WHETHER IT IS A DIRECTLY RELATED CONVICTION, AS DEFINED IN SECTION 24-116 OF THIS CODE, THAT HAS DIRECT AND SPECIFIC NEGATIVE BEARING ON THE SAFETY OF PERSONS OR REAL PROPERTY; AND

(4) ANY EVIDENCE OF INACCURACY OR EVIDENCE OF REHABILITATION OR OTHER MITIGATING FACTORS PRESENTED BY THE APPLICANT.

(C) IF A HOUSING PROVIDER INTENDS TO BASE AN ADVERSE ACTION RELATED TO ELIGIBLE HOUSING ON AN ITEM OR ITEMS IN THE APPLICANT'S CONVICTION HISTORY, PRIOR TO TAKING ANY ADVERSE ACTION THE HOUSING PROVIDER SHALL PROVIDE THE APPLICANT WITH A COPY OF THE BACKGROUND CHECK REPORT AND SHALL NOTIFY THE APPLICANT OF THE PROSPECTIVE ADVERSE ACTION AND THE ITEMS FORMING THE BASIS FOR THE PROSPECTIVE ADVERSE ACTION.

(D) IF, WITHIN 14 CALENDAR DAYS OF THE DATE THAT THE NOTICE DESCRIBED IN SUBSECTION (C) OF THIS SECTION IS PROVIDED BY THE HOUSING PROVIDER TO THE APPLICANT, THE APPLICANT GIVES THE HOUSING PROVIDER NOTICE IN WRITING OF EVIDENCE OF THE INACCURACY OF THE ITEM OR ITEMS OF CONVICTION HISTORY OR EVIDENCE OF REHABILITATION OR OTHER MITIGATING FACTORS SET FORTH IN THIS SECTION, THE HOUSING PROVIDER SHALL DELAY ANY ADVERSE ACTION FOR A REASONABLE PERIOD OF NOT LESS THAN FIVE CALENDAR DAYS AFTER RECEIPT OF THE INFORMATION. DURING THAT TIME THE HOUSING PROVIDER SHALL RECONSIDER THE PROSPECTIVE ADVERSE ACTION IN LIGHT OF THE INFORMATION PROVIDED BY THE APPLICANT OR POTENTIAL APPLICANT.

(E) THE HOUSING PROVIDER SHALL PROMPTLY NOTIFY THE APPLICANT OF ANY FINAL ADVERSE ACTION BASED UPON THEIR CONVICTION HISTORY OR CONTENTS OF THE CRIMINAL BACKGROUND CHECK.

(F) IT SHALL BE UNLAWFUL FOR ANY HOUSING PROVIDER TO ENGAGE IN ANY COMMUNICATION, INCLUDING THE PRODUCTION OR DISSEMINATION OF ADVERTISEMENTS, RELATED TO ELIGIBLE HOUSING, WHICH EXPRESSES, DIRECTLY OR INDIRECTLY, THAT ANY PERSON WITH AN ARREST OR CONVICTION RECORD WILL NOT BE CONSIDERED FOR THE RENTAL OR LEASE OF REAL PROPERTY OR THAT MAY NOT APPLY FOR THE RENTAL OR LEASE OF REAL PROPERTY, EXCEPT AS REQUIRED BY LOCAL, STATE, OR FEDERAL LAW. FOR PURPOSES OF THIS SUBSECTION, ENGAGING IN A COMMUNICATION INCLUDES, BUT IS NOT LIMITED TO, MAKING A VERBAL STATEMENT OR PRODUCING OR DISSEMINATING ANY SOLICITATION, ADVERTISEMENT, OR SIGNAGE.

§24-121 NOTICE AND POSTING REQUIREMENTS FOR HOUSING PROVIDERS.

(A) A HOUSING PROVIDER SHALL STATE IN ALL SOLICITATIONS OR ADVERTISEMENTS FOR THE RENTAL OR LEASE OF ELIGIBLE HOUSING, OR MADE ON THEIR BEHALF, THAT THE HOUSING PROVIDER SHALL CONSIDER QUALIFIED APPLICANTS CONSISTENT WITH THIS ARTICLE. THIS LANGUAGE SHALL INCLUDE, AT MINIMUM, THE FOLLOWING STATEMENT:

"THE RENTAL OR LEASE OF THIS PROPERTY MUST COMPLY WITH CHAPTER 24, ARTICLE IV OF THE FLINT CITY CODE OF ORDINANCES REGULATING THE USE OF CRIMINAL BACKGROUND CHECKS AS PART OF THE TENANT SCREENING PROCESS TO PROVIDE CITIZENS WITH CRIMINAL BACKGROUNDS A FAIR OPPORTUNITY. FOR ADDITIONAL INFORMATION, PLEASE CONTACT THE CITY OF FLINT OFFICE OF THE OMBUDSPERSON."

(B) THE ADMINISTERING AGENCY SHALL PUBLISH AND MAKE AVAILABLE TO HOUSING PROVIDERS, IN ALL LANGUAGES SPOKEN BY MORE THAN FIVE PERCENT OF THE CITY'S POPULATION, A NOTICE SUITABLE FOR POSTING THAT INFORMS APPLICANTS FOR ELIGIBLE HOUSING OF THEIR RIGHTS UNDER THIS ARTICLE. THIS NOTICE SHALL BE UPDATED ON OR BEFORE DECEMBER 1ST OF ANY YEAR WHEN THERE IS A CHANGE IN THE LANGUAGES SPOKEN BY MORE THAN FIVE PERCENT OF THE CITY'S POPULATION.

(C) IN ADDITION TO THE REQUIREMENTS FOR SOLICITATIONS OR ADVERTISEMENTS IN SUBSECTION (A) OF THIS SECTION, HOUSING PROVIDERS SHALL POST A NOTICE PROMINENTLY ON THEIR WEBSITE AND AT ANY LOCATION UNDER THEIR CONTROL THAT IS FREQUENTLY VISITED BY APPLICANTS OR POTENTIAL APPLICANTS FOR THE RENTAL OR LEASE OF ELIGIBLE HOUSING IN THE CITY. IN ADDITION, THIS NOTICE SHALL BE AVAILABLE TO APPLICANTS IN HARD COPY AND PROVIDED WITH AN APPLICATION. THE NOTICE REQUIREMENTS IN THIS SECTION SHALL CONTAIN THE FOLLOWING ADDITIONAL INFORMATION, WHICH MAY BE SUMMARIZED BY THE HOUSING PROVIDER OR AVAILABLE FROM THE ADMINISTERING AGENCY PURSUANT TO SECTION 24-127(A)(1) OF THIS CODE:

(1) A DESCRIPTION OF THOSE MATTERS IDENTIFIED IN SECTION 24-118 OF THIS CODE THAT MAY NOT BE CONSIDERED BY THE HOUSING PROVIDER;

(2) A DESCRIPTION OF THE RESTRICTIONS AND REQUIREMENTS THAT SECTION 24-118 OF THIS CODE IMPOSES ON HOUSING PROVIDERS WHEN INQUIRING ABOUT CONVICTION HISTORY IN CONNECTION WITH AN APPLICATION FOR THE RENTAL OR LEASE OF ELIGIBLE HOUSING IN THE CITY;

(3) THE CIRCUMSTANCES AND TIMELINE UNDER WHICH THE APPLICANT OR POTENTIAL APPLICANT HAS A RIGHT TO PROVIDE EVIDENCE OF REHABILITATION AND OTHER MITIGATING FACTORS AS PROVIDED IN SECTION 24-120 OF THIS CODE; AND

(4) THE TELEPHONE NUMBER, EMAIL ADDRESS, AND MAILING ADDRESS OF THE ADMINISTERING AGENCY THAT THE APPLICANT OR POTENTIAL APPLICANT MAY USE TO MAKE A REPORT WHERE HE OR SHE BELIEVES THE HOUSING PROVIDER HAS VIOLATED THIS ARTICLE IN THEIR INTERACTIONS WITH THE APPLICANT OR POTENTIAL APPLICANT.

§24-122 HOUSING PROVIDER RECORDS.

(A) UNLESS PROHIBITED BY FEDERAL OR STATE LAW, A HOUSING PROVIDER SHALL MAINTAIN AND RETAIN RECORDS OF TENANT APPLICATION FORMS, AND OTHER PERTINENT DATA AND RECORDS REQUIRED UNDER THIS ARTICLE, FOR A MINIMUM OF ONE YEAR FROM THE DATE OF APPLICATION, AND SHALL ALLOW THE ADMINISTERING OR ENFORCING AGENCIES ACCESS TO SUCH RECORDS, WITH APPROPRIATE NOTICE AND AT A MUTUALLY AGREEABLE TIME, TO MONITOR OR VERIFY COMPLIANCE WITH THE REQUIREMENTS OF THIS ARTICLE.

(B) AT NO TIME SHALL THE ADMINISTERING OR ENFORCING AGENCIES REQUIRE A HOUSING PROVIDER TO PROVIDE THE DISCLOSURE OF ANY INFORMATION OR DOCUMENTS, WHICH WOULD VIOLATE STATE OR FEDERAL LAW, OR THIS CODE.

(C) WHERE A HOUSING PROVIDER DOES NOT MAINTAIN OR PROVIDE ADEQUATE RECORDS DOCUMENTING COMPLIANCE WITH THIS ARTICLE OR DOES NOT ALLOW REASONABLE ACCESS TO SUCH RECORDS, THE OFFICE OF THE CHIEF FINANCIAL OFFICER OR OTHER CITY DEPARTMENT OR AGENCY SHALL HAVE THE AUTHORITY TO PROVIDE ALL NON-FINANCIAL INFORMATION NECESSARY TO FULFILL THE ADMINISTERING OR ENFORCING AGENCIES RESPONSIBILITIES UNDER THIS ARTICLE SUBJECT TO CONFIDENTIALITY PROVISIONS OF THIS ARTICLE AND ALL APPLICABLE LAWS.

§24-123 EXERCISE OF PROTECTED RIGHTS; RETALIATION PROHIBITED.

(A) IT SHALL BE UNLAWFUL FOR A HOUSING PROVIDER OR ANY OTHER PERSON TO INTERFERE WITH, RESTRAIN, OR DENY THE EXERCISE OF, OR THE ATTEMPT TO EXERCISE, ANY RIGHT PROVIDED UNDER THIS ARTICLE.

(B) IT SHALL BE UNLAWFUL FOR A HOUSING PROVIDER TO INTERRUPT, TERMINATE, OR FAIL OR REFUSE TO INITIATE OR CONDUCT A TRANSACTION INVOLVING THE RENTAL OR LEASE OF ELIGIBLE HOUSING, INCLUDING FALSELY REPRESENTING THAT SUCH PROPERTY IS NOT AVAILABLE FOR RENTAL OR LEASE, OR OTHERWISE TAKE ADVERSE ACTION AGAINST A PERSON IN RETALIATION FOR EXERCISING RIGHTS PROTECTED UNDER THIS ARTICLE. SUCH RIGHTS INCLUDE BUT ARE NOT LIMITED TO:

(1) THE RIGHT TO FILE A COMPLAINT OR INFORM ANY PERSON ABOUT A HOUSING PROVIDER'S ALLEGED VIOLATION OF THIS ARTICLE;

(2) THE RIGHT TO INFORM THE ADMINISTERING AGENCY ABOUT A HOUSING PROVIDER'S ALLEGED VIOLATION OF THIS ARTICLE;

(3) THE RIGHT TO COOPERATE WITH THE ADMINISTERING OR ENFORCING AGENCIES OR OTHER PERSONS IN THE INVESTIGATION OR PROSECUTION OF ANY ALLEGED VIOLATION OF THIS ARTICLE; OR

(4) THE RIGHT TO INFORM ANY PERSON OF HIS OR HER RIGHTS UNDER THIS ARTICLE.

(C) PROTECTIONS OF THIS SECTION SHALL APPLY TO ANY PERSON WHO MISTAKENLY, BUT IN GOOD FAITH, ALLEGES VIOLATIONS OF THIS ARTICLE.

(D) TAKING ADVERSE ACTION AGAINST A PERSON WITHIN 90 CALENDAR DAYS OF THE EXERCISE OF ONE OR MORE OF THE RIGHTS DESCRIBED IN THIS SECTION SHALL CREATE A REBUTTABLE PRESUMPTION IN THE ADMINISTERING AGENCY'S INVESTIGATION THAT SUCH ADVERSE ACTION WAS TAKEN IN RETALIATION FOR THE EXERCISE OF THOSE RIGHTS.

§24-124 COMMUNITY OUTREACH.

(A) THE ADMINISTERING AGENCY MAY ESTABLISH A COMMUNITY-BASED OUTREACH PROGRAM TO CONDUCT EDUCATION AND OUTREACH TO APPLICANTS AND POTENTIAL APPLICANTS FOR HOUSING REGARDING RIGHTS AND PROCEDURES UNDER THIS ARTICLE. THE PROGRAM MAY BE TARGETED AT INDIVIDUALS OR COMMUNITIES WHERE, IN THE JUDGMENT OF THE ADMINISTERING AGENCY, THE NEED FOR EDUCATION AND OUTREACH IS GREATEST.

(B) IN ESTABLISHING AN OUTREACH PROGRAM PURSUANT TO SUBSECTION (A) OF THIS SECTION, THE ADMINISTERING AGENCY MAY PARTNER WITH COMMUNITY-BASED ORGANIZATIONS. NOTHING IN THIS SECTION SHALL PRECLUDE THE ADMINISTERING AGENCY, BY CONTRACT OR GRANT, AND CONSISTENT WITH OTHER PROVISIONS OF LOCAL LAWS, FROM ENGAGING THE SERVICES OF SUCH ORGANIZATIONS IN ESTABLISHING SUCH COMMUNITY-BASED OUTREACH PROGRAMS, PARTICIPATING IN SUCH PROGRAMS, OR DEVELOPING MATERIALS FOR SUCH PROGRAMS. NOTHING IN THIS SECTION SHALL PRECLUDE THE ADMINISTERING AGENCY FROM COMBINING THE OUTREACH PROGRAMS REQUIRED BY SUBSECTION (A) OF THIS SECTION WITH OTHER RELATED COMMUNITY OUTREACH PROGRAMS.

§24-125 CONFIDENTIALITY

THE CITY SHALL KEEP CONFIDENTIAL, TO THE EXTENT PERMITTED BY APPLICABLE LAWS, ANY IDENTIFYING INFORMATION OR OTHER DATA PERTAINING TO AN APPLICANT'S CRIMINAL HISTORY.

§24-126 IMPLEMENTATION AND ENFORCEMENT; PENALTIES

(A) THE ADMINISTERING AGENCY SHALL INVESTIGATE COMPLAINTS REGARDING A HOUSING PROVIDER'S ALLEGED VIOLATION OF THIS ARTICLE. THE ADMINISTRATIVE AGENCY MAY ENGAGE THIRD-PARTY ASSISTANCE TO CONDUCT ITS INVESTIGATION.

(1) WHERE THE DIRECTOR OF THE ADMINISTERING AGENCY DETERMINES THAT A VIOLATION HAS NOT OCCURRED, HE OR SHE SHALL ISSUE A DETERMINATION THAT A HOUSING PROVIDER IS NOT IN VIOLATION OF THIS ARTICLE. THIS DETERMINATION SHALL BE PROVIDED TO THE HOUSING PROVIDER AND THE COMPLAINANT.

(2) WHERE THE DIRECTOR OF THE ADMINISTERING AGENCY DETERMINES THAT A VIOLATION HAS OCCURRED, HE OR SHE SHALL ISSUE A DETERMINATION THAT A HOUSING PROVIDER IS IN VIOLATION OF THIS ARTICLE, PROVIDED, HOWEVER, FOR A FIRST VIOLATION, OR FOR ANY VIOLATION DURING THE FIRST 12 MONTHS FOLLOWING THE EFFECTIVE DATE OF THIS ARTICLE, THE DIRECTOR MUST ISSUE WARNINGS AND NOTICES TO CORRECT, AND OFFER THE HOUSING PROVIDER TECHNICAL ASSISTANCE ON HOW TO COMPLY WITH THE REQUIREMENTS OF THIS ARTICLE. FOR A SECOND VIOLATION, THE ADMINISTERING AGENCY SHALL REFER ITS DETERMINATION FOR EACH APPLICANT TO WHOM THE VIOLATION OCCURRED, OR IS CONTINUING, TO THE ENFORCING AGENCY FOR ACTION, TO THE HOUSING PROVIDER, AND TO THE COMPLAINANT.

(3) WHERE THE DIRECTOR OF THE ADMINISTERING AGENCY DETERMINES THAT A VIOLATION HAS OCCURRED, HE OR SHE SHALL FORWARD A COPY OF THE DETERMINATION TO THE MICHIGAN DEPARTMENT OF CIVIL RIGHTS FOR CONSIDERATION.

(B) THE ADMINISTERING AGENCY IS AUTHORIZED TO TAKE APPROPRIATE STEPS TO ASSIST IN THE ENFORCEMENT OF THIS

ARTICLE, INCLUDING THE INVESTIGATION OF ANY POSSIBLE VIOLATIONS OF THIS ARTICLE. THE ADMINISTERING OR ENFORCING AGENCIES SHALL NOT FIND A VIOLATION BASED ON A HOUSING PROVIDER'S DECISION THAT AN APPLICANT'S CONDUCT IS A DIRECTLY-RELATED CONVICTION, AS DEFINED IN SECTION 24-116 OF THIS CODE, UNLESS THE HOUSING PROVIDER FAILED TO CONDUCT THE INDIVIDUALIZED ASSESSMENT AS REQUIRED UNDER SECTION 24-120 OF THIS CODE.

(C) IF MULTIPLE APPLICANTS ARE IMPACTED BY THE SAME VIOLATION AT THE SAME TIME, FOR EXAMPLE, ALL APPLICANTS FOR A CERTAIN HOUSING UNIT ARE ASKED FOR THEIR CONVICTION HISTORY ON THE INITIAL APPLICATION, EACH VIOLATION SHALL BE TREATED AS A SEPARATE VIOLATION.

(d) IN ACCORDANCE WITH SECTION 4I(K) OF THE MICHIGAN HOME RULE CITIES ACT, BEING MCL. 117.4I(K), THE PENALTY UPON CONVICTION FOR VIOLATION OF THIS ARTICLE SHALL BE IMPRISONMENT FOR NOT MORE THAN 90 DAYS OR A FINE OF NOT MORE THAN \$500.00, OR BOTH, FOR EACH SUCH VIOLATION, IN THE DISCRETION OF THE COURT.

(E) AN APPLICANT OR POTENTIAL APPLICANT MAY REPORT TO THE ADMINISTERING AGENCY ANY SUSPECTED VIOLATION OF THIS ARTICLE WITHIN 60 CALENDAR DAYS OF THE DATE THE SUSPECTED VIOLATION OCCURRED. THE CITY SHALL ENCOURAGE REPORTING PURSUANT TO THIS SUBSECTION BY KEEPING CONFIDENTIAL, TO THE MAXIMUM EXTENT PERMITTED BY APPLICABLE LAW; THE NAME AND OTHER IDENTIFYING INFORMATION OF THE APPLICANT OR POTENTIAL APPLICANT REPORTING THE VIOLATION, PROVIDED, HOWEVER, THAT WITH THE AUTHORIZATION OF SUCH PERSON, THE CITY MAY DISCLOSE HIS OR HER NAME AND IDENTIFYING INFORMATION AS NECESSARY TO ENFORCE THIS ARTICLE OR FOR OTHER APPROPRIATE PURPOSES, WHICH SHALL INCLUDE ENABLING THE HOUSING PROVIDER TO RESPOND TO THE ALLEGED VIOLATION AS PART OF AN INVESTIGATION BY THE ADMINISTERING AGENCY.

§24-127 IMPLEMENTATION AND ENFORCEMENT; ADMINISTRATIVE RULES AND ANNUAL REPORTING REQUIREMENTS.

(A) WITHIN 120 CALENDAR DAYS AFTER THE EFFECTIVE DATE OF THIS ARTICLE, THE ADMINISTERING AGENCY SHALL PROMULGATE ADMINISTRATIVE RULES PURSUANT TO SECTION 1-801 OF THE FLINT CITY CHARTER. THESE RULES SHALL INCLUDE, AT MINIMUM, PROCEDURES FOR THE FOLLOWING:

(1) PREPARING STANDARDIZED LANGUAGE FOR THE NOTICE IN SECTION 24-121(C) OF THIS CODE THAT HOUSING PROVIDERS MAY USE TO SATISFY THE REQUIREMENTS OF THAT SUBSECTION.

(2) TIMEFRAME AND PROCESS, INCLUDING NOTIFICATION, FOR THE FOLLOWING:

A. TO HOUSING PROVIDERS THAT A COMPLAINT HAS BEEN FILED ALLEGING VIOLATION OF THIS ARTICLE AND THAT AN INVESTIGATION WILL OCCUR;

B. TO PROVIDE THE HOUSING PROVIDER A RIGHT TO RESPOND TO THE ALLEGATIONS IN THE COMPLAINT;

C. TO OBTAIN VERIFICATION FROM THE BUILDING & SAFETY INSPECTIONS DIVISION THAT THE ELIGIBLE HOUSING IS IN COMPLIANCE WITH THE REGISTRATION OF RESIDENTIAL RENTAL PROPERTIES IN ACCORDANCE WITH SECTION 24-4, *ET SEQ.* OF THIS CODE;

D. TO OBTAIN VERIFICATION FROM THE BUILDING & SAFETY INSPECTIONS DIVISION THAT THE ELIGIBLE HOUSING HAS A VALID CERTIFICATE OF COMPLIANCE REQUIRED BY SECTION 24-4, *ET SEQ.* OF THIS CODE OR BY OTHER PROVISIONS OF THIS CODE;

E. RECEIPT AND CONSIDERATION BY THE ADMINISTERING AGENCY OF ANY RESPONSE AND SUPPORTING INFORMATION FROM A HOUSING PROVIDER REGARDING THE ALLEGED VIOLATION; AND

F. DISSEMINATION OF THE ADMINISTERING AGENCY'S DETERMINATION OF WHETHER AN ALLEGED VIOLATION IN THE COMPLAINT WAS SUBSTANTIATED TO THE HOUSING PROVIDER AND COMPLAINANT. IF A VIOLATION IS SUBSTANTIATED, DISSEMINATION TO THE ENFORCING AGENCY AND MICHIGAN DEPARTMENT OF CIVIL RIGHTS.

(B) THE ADMINISTERING AND ENFORCING AGENCIES SHALL PREPARE AND JOINTLY SUBMIT AN ANNUAL REPORT TO THE MAYOR AND CITY COUNCIL THAT INCLUDES, AT A MINIMUM, THE FOLLOWING INFORMATION FOR THE PRECEDING YEAR:

(1) THE NUMBER AND TYPES OF COMPLAINTS RECEIVED ALLEGING VIOLATIONS OF THIS ARTICLE;

(2) THE NUMBER AND TYPES OF VIOLATIONS OF THIS ARTICLE REPRESENTED BY THE NUMBER OF DETERMINATIONS ISSUED BY THE DIRECTOR OF THE ADMINISTERING AGENCY SUBSTANTIATING THE ALLEGED VIOLATIONS;

3) THE NUMBER AND TYPES OF VIOLATIONS OF THIS ARTICLE REPRESENTED BY THE NUMBER OF DETERMINATIONS ISSUED BY THE DIRECTOR OF THE ADMINISTERING AGENCY WHERE THE ALLEGATIONS OF VIOLATIONS OF THIS ARTICLE WERE UNSUBSTANTIATED;

(4) THE NUMBER AND TYPES OF DETERMINATIONS FORWARDED TO THE MICHIGAN DEPARTMENT OF CIVIL RIGHTS;

(5) THE NUMBER AND TYPES OF TICKETS BY THE ENFORCING AGENCY;

(6) DATA REGARDING THE JUDICIAL DISPOSITION OF TICKETS ISSUED BY THE ENFORCING AGENCY ITEMIZING THE NUMBER OF DISMISSALS, CONVICTIONS OR PLEA ARRANGEMENTS, INCLUDING THE PENALTIES ASSESSED; AND

(7) THE COSTS ASSOCIATED WITH THE IMPLEMENTATION AND ADMINISTRATION OF THIS ARTICLE.

Sec 2. This Ordinance shall become effective this _____ day of _____, 2024, A.D.

Adopted this _____ day of _____, 2024, A.D.

FOR THE CITY:

For the City Council

Sheldon A. Neeley, Mayor

APPROVED AS TO FORM:

JoAnne Gurley, Chief Legal Officer

240430.1-T

ORDINANCE NO. _____

AN ORDINANCE TO AMEND THE FLINT CITY CODE OF ORDINANCES BY AMENDING CHAPTER 25.

IT IS HEREBY ORDAINED BY THE PEOPLE OF THE CITY OF FLINT:

SEC. 1. AN ORDINANCE TO AMEND THE FLINT CITY CODE OF ORDINANCES BY AMENDING CHAPTER 25, COMMUNITY DEVELOPMENT, BY ADDING ARTICLE I, COMMUNITY BENEFITS AGREEMENTS, BY ADDING SECTIONS 25-1 THROUGH 25-7, WHICH SHALL READ IN THEIR ENTIRETY AS FOLLOWS:

§25-1. PURPOSE.

- (1) IT SHALL BE THE POLICY OF THE CITY OF FLINT TO REQUIRE, WHEREVER FEASIBLE, PROPORTIONAL COMMUNITY BENEFITS AS A CONDITION OF SIGNIFICANT PUBLIC SUPPORT FOR DEVELOPMENT IN THE FORM OF SUBSIDIES, TAX ABATEMENTS, BELOW-MARKET PRICED LAND, OR OTHER ENHANCED PUBLIC RESOURCES.
- (2) THIS ARTICLE SHALL BE KNOWN AS THE "CITY OF FLINT COMMUNITY BENEFITS ORDINANCE."

§25-2. DEFINITIONS.

THE FOLLOWING WORDS, TERMS, AND PHRASES WHEN USED IN THIS ARTICLE SHALL HAVE THE MEANINGS ASCRIBED TO THEM IN THIS SECTION, EXCEPT WHERE THE CONTEXT CLEARLY INDICATES A DIFFERENT MEANING:

COMMUNITY BENEFITS MEAN THE AMENITIES, BENEFITS, COMMITMENTS, OR PROMISES TO THE CITY OF FLINT BY A DEVELOPER, AS DISCUSSED FURTHER IN THIS ORDINANCE.

COMMUNITY BENEFITS AGREEMENT MEANS A VOLUNTARY CONTRACT NEGOTIATED AND AGREED TO BY THE CITY OF FLINT AND A DEVELOPER TO PROVIDE COMMUNITY BENEFITS IN RETURN FOR THE RECEIPT OF PUBLIC SUPPORT.

DEPARTMENT MEANS THE CITY OF FLINT DEPARTMENT OF BUSINESS & COMMUNITY SERVICES, OR ITS SUCCESSOR DEPARTMENT.

CITYWIDE ADVISORY COUNCIL MEANS THE CITYWIDE ADVISORY COUNCIL CHARGED WITH NEGOTIATING THE COMMUNITY BENEFITS AGREEMENTS AND WILL INCLUDE TWO MEMBERS OF THE AFFECTED WARD(S).

ENFORCEMENT COMMITTEE MEANS A COMMITTEE ESTABLISHED TO MONITOR AND ENFORCE THE COMMUNITY BENEFITS AGREEMENT BETWEEN THE CITY OF FLINT AND THE DEVELOPER, ITS AGENTS, ASSIGNEES, OR DESIGNEES.

DEVELOPER MEANS ANY FOR PROFIT PERSON, FIRM, PARTNERSHIP, LIMITED LIABILITY COMPANY, CORPORATION, JOINT VENTURE, PROPRIETORSHIP, OR OTHER ENTITY THAT IS THE PURCHASER OR LESSEE IN THE SALE OR LEASE OF CITY- OWNED LAND, THE RECIPIENT OF A FINANCIAL INCENTIVE, OR ANY COMBINATION THEREOF, INCLUDING SUB-CONTRACTORS.

IMPACT AREA MEANS AN AREA DETERMINED BY THE DIRECTOR OF BUSINESS AND COMMUNITY SERVICES THAT INCLUDES ALL CENSUS TRACTS OR CENSUS BLOCK GROUPS WITHIN THE AFFECTED WARD(S) IN WHICH THE PROJECT IS LOCATED.

DIRECTOR MEANS THE DIRECTOR OF THE CITY OF FLINT'S DEPARTMENT OF BUSINESS & COMMUNITY SERVICES.

FINANCIAL INCENTIVE MEANS CASH OR NEAR-CASH ASSISTANCE PROVIDED ON THE DISCRETIONARY BASIS BY THE CITY OF FLINT TO ATTRACT OR RETAIN A PROJECT. THESE BENEFITS PRINCIPALLY ENCOMPASS TAX AND ECONOMIC INCENTIVES PROVIDED BY FEDERAL, STATE, OR LOCAL GOVERNMENTAL BODIES.

INTERESTED PARTIES MEANS THE RESIDENTS OF THE WARD(S) IN WHICH A PROJECT IS PROPOSED TO BE LOCATED.

PROJECT MEANS EITHER A TIER 1 PROJECT, TIER 2 PROJECT, OR TIER 3 PROJECT.

PUBLIC SUPPORT MEANS A FINANCIAL INCENTIVE OR THE SALE OR LEASE OF CITY-OWNED LAND BELOW MARKET VALUE, AS DETERMINED BY THE CITY ASSESSOR. PUBLIC SUPPORT SHALL NOT INCLUDE INCENTIVES THROUGH THE NEIGHBORHOOD ENTERPRISE ZONE ACT, PUBLIC ACT 147 OF 1992 (MCL 207.771 ET SEQ).

QUADRUPLE BOTTOM LINE PHILOSOPHY MEANS THE EFFECT A PROJECT MAY HAVE ON THE WELL-BEING OF THE COMMUNITY IN TERMS OF CULTURAL VITALITY, SOCIAL EQUITY, ECONOMIC PROSPERITY, AND ENVIRONMENTAL SUSTAINABILITY. THIS INCLUDES THE PUBLIC SUPPORT AND COMMUNITY BENEFITS AGREED TO AS PART OF THE PROJECT.

REGISTERED GROUP MEANS ANY GROUP OR ORGANIZATION WITH AT LEAST ONE MEMBER THAT IS A RESIDENT OF THE CITY OF FLINT THAT FILES THEIR CONTACT INFORMATION WITH THE OFFICE OF BUSINESS AND COMMUNITY SERVICES TO RECEIVE NOTIFICATION UNDER THIS ORDINANCE. THE OFFICE OF BUSINESS AND COMMUNITY SERVICES SHALL KEEP THIS INFORMATION ON FILE. THE REGISTERED GROUP SHALL BE RESPONSIBLE FOR THE ACCURACY OF THE INFORMATION SUBMITTED TO THE DEPARTMENT.

SALE OR LEASE OF CITY-OWNED LAND MEANS THE CONVEYANCE OF TITLE OF REAL PROPERTY FROM THE CITY OR OTHER PUBLIC ENTITY TO A PURCHASER OR A LEASE OF CITY OR OTHER PUBLIC PROPERTY TO A LESSEE. THE CONVEYANCE OF CITY RIGHT-OF-WAYS, CONVEYANCES UNDER THE PROPERTY DISPOSITION POLICY, AND THE CONVEYANCE OR LEASE OF PROPERTIES LESS THAN ONE-QUARTER (1/4) OF AN ACRE IN SIZE ARE NOT INCLUDED IN THIS DEFINITION.

TIER 1 PROJECT MEANS ANY PROJECT, DEVELOPMENT, OR REDEVELOPMENT IN WHICH THE DEVELOPER IS REQUESTING PUBLIC SUPPORT IN THE FORM OF FINANCIAL INCENTIVES OR IN THE FORM OF THE SALE OR LEASE OF CITY- OWNED LAND FOR A PROJECT ESTIMATED AT 20 MILLION DOLLARS OR MORE AT THE TIME OF THE FIRST PUBLIC HEARING.

(1) ANY TRANSFER TO THE DEVELOPER OF CITY-OWNED LAND PARCELS THAT HAVE A CUMULATIVE MARKET VALUE OF \$1,000,000.00 OR MORE, AS DETERMINED BY THE CITY ASSESSOR OR INDEPENDENT APPRAISAL, WITHOUT OPEN BIDDING AND PRICED BELOW MARKET RATES WHERE ALLOWED BY LAW; OR

(2) PROVISION OR APPROVAL BY THE CITY OF TAX ABATEMENTS OR OTHER TAX BREAKS THAT ABATE MORE THAN \$1,000,000.00 OF CITY TAXES OVER THE TERM OF THE ABATEMENT THAT INURE DIRECTLY TO THE DEVELOPER, BUT NOT INCLUDING NEIGHBORHOOD ENTERPRISE ZONE TAX ABATEMENTS.

TIER 2 PROJECT MEANS ANY PROJECT, DEVELOPMENT, OR REDEVELOPMENT IN WHICH THE DEVELOPER IS REQUESTING PUBLIC SUPPORT IN THE FORM OF A FINANCIAL INCENTIVES OR IN THE FORM OF THE SALE OR LEASE OF CITY-OWNED LAND FOR A PROJECT ESTIMATED AT 1 MILLION DOLLARS OR MORE AT THE TIME OF THE FIRST PUBLIC HEARING.

(1) ANY TRANSFER TO THE DEVELOPER OF CITY OWNED LAND PARCELS THAT HAVE A CUMULATIVE MARKET VALUE OF \$150,000.00 OR MORE, AS DETERMINED BY THE CITY ASSESSOR OR INDEPENDENT APPRAISAL, WITHOUT OPEN BIDDING AND PRICED BELOW MARKET RATES WHERE ALLOWED BY LAW; OR

(2) PROVISIONS OR APPROVAL BY THE CITY OF TAX ABATEMENTS THAT ABATE MORE THAN \$150,000.00 OF CITY TAXES OVER THE TERM OF THE ABATEMENT THAT INURE DIRECTLY TO THE DEVELOPER, BUT NOT INCLUDING NEIGHBORHOOD ENTERPRISE ZONE TAX ABATEMENT.

TIER 3 PROJECT MEANS ANY PROJECT, DEVELOPMENT, OR REDEVELOPMENT IN WHICH THE DEVELOPER IS REQUESTING PUBLIC SUPPORT IN THE FORM OF FINANCIAL INCENTIVES OR IN THE FORM OF THE SALE OR LEASE OF CITY-OWNED LAND FOR SPECIFIC PROJECTS ESTIMATED TO BE BELOW 1 MILLION DOLLARS AT THE TIME OF THE FIRST PUBLIC HEARING.

(1) ANY LAND TRANSFER TO THE DEVELOPER OF CITY OWNED LAND PARCELS THAT HAVE A CUMULATIVE MARKET VALUE OF \$25,000.00 OR MORE, AS DETERMINED BY THE CITY ASSESSOR OR INDEPENDENT APPRAISAL, WITHOUT OPEN BIDDING AND PRICED BELOW MARKET RATES WHERE ALLOWED BY LAW; OR

(2) PROVISIONS OR APPROVAL BY THE CITY OF TAX ABATEMENTS THAT ABATE MORE THAN \$25,000.00 OF CITY TAXES OVER THE TERM OF THE ABATEMENT THAT INURE DIRECTLY TO THE DEVELOPER, BUT NOT INCLUDING NEIGHBORHOOD ENTERPRISE ZONE TAX ABATEMENT.

§25-3. COMMUNITY BENEFITS AGREEMENT REQUIRED.

(A) A COMMUNITY BENEFITS AGREEMENT IS REQUIRED BETWEEN THE CITY OF FLINT AND A DEVELOPER CONSISTENT WITH TIER 1, TIER 2, AND TIER 3 AS DEFINED IN SECTION 25-2 OF THIS ORDINANCE PRIOR TO THE CITY COUNCIL'S FINAL APPROVAL OF PUBLIC SUPPORT. THE CITY COUNCIL MAY GRANT PRELIMINARY APPROVAL OF PUBLIC SUPPORT SUBJECT TO THE EXECUTION OF A COMMUNITY BENEFITS AGREEMENT.

(B) THE CITY COUNCIL MUST ACCEPT OR AMEND A FINAL COMMUNITY BENEFITS AGREEMENT WITHIN 28 DAYS AFTER PRESENTMENT TO THE CITY COUNCIL BY RESOLUTION. THE COMMUNITY BENEFITS AGREEMENT WILL TAKE EFFECT IF NO ACTION IS TAKEN BY THE CITY COUNCIL AFTER 28 DAYS.

(C) THE FOLLOWING MINIMUM STANDARDS SHALL BE REQUIRED OF ANY COMMUNITY BENEFITS AGREEMENT CONTRACT:

(1) SHALL INCORPORATE, TO THE EXTENT PRACTICABLE, THE QUADRUPLE BOTTOM LINE PHILOSOPHY AS DEFINED IN SECTION 25-2 OF THIS ORDINANCE: THE EFFECT A PROJECT MAY HAVE ON THE WELL-BEING OF THE COMMUNITY IN TERMS OF CULTURAL VITALITY, SOCIAL EQUITY, ECONOMIC PROSPERITY, AND ENVIRONMENTAL SUSTAINABILITY. THIS INCLUDES THE PUBLIC SUPPORT AND COMMUNITY BENEFITS AGREED TO AS PART OF THE PROJECT.

(2) LEGALLY ENFORCEABLE AND THE RESULT OF THE PROCEDURE SPECIFIED UNDER THE PROVISIONS OF THIS ARTICLE.

(3) THE COMMUNITY BENEFITS PROVIDED REFLECT THE SCALE OF AND ARE IN PROPORTION TO THE PUBLIC SUPPORT APPROVED.

(4) IDENTIFY SPECIFIC METHODS FOR MONITORING AND COMPLIANCE WITH THE PROVISIONS OF THE COMMUNITY BENEFITS AGREEMENT.

- (5) PROVIDE FOR ENFORCEMENT TERMS AND SPECIFIC REMEDIES UPON THE BREACH OR NONCOMPLIANCE OF A PARTY. SUCH REMEDIES MAY INCLUDE, WITHOUT LIMITATION, SPECIFIC PERFORMANCE, LIQUIDATED DAMAGES, CLAW BACKS OF FINANCIAL INCENTIVES AND/OR LAND, OR THE REVOCATION OR WITHDRAWAL OF PUBLIC SUPPORT.
- (6) THE PROVISIONS OF A COMMUNITY BENEFITS AGREEMENT SHALL BE BINDING UPON ALL PARTIES, INCLUDING THEIR AGENTS, SUCCESSORS, AND ASSIGNS. AFTER APPROVAL AND EXECUTION BY THE PARTIES, COMMUNITY BENEFITS AGREEMENTS SHALL BE RECORDED AGAINST THE PROPERTY IN WHICH A PROJECT IS LOCATED AND RUN WITH THE LAND.
- (7) WHERE POSSIBLE, PROVIDE MEANS TO MEASURE, VALUE, AND ASSESS THE FACTORS DISCUSSED TIER 1, TIER 2, AND TIER 3 PROJECTS TO THE CITYWIDE ADVISORY COUNCIL.
- (8) INCLUSION OF LOCAL SMALL BUSINESSES, MINORITY-OWNED BUSINESS ENTERPRISES, WOMEN OWNED BUSINESS ENTERPRISES, AND OTHER RELEVANT BUSINESS ORGANIZATIONS IN PRE-BID MEETINGS AND CONFERENCES WITH ADVANCE NOTICE.
- (9) COMPLIANCE OF DEVELOPER WITH ANY COMPETITIVE REQUIREMENTS, AS APPLICABLE, PROVIDED FOR IN THE CITY CODE OF ORDINANCES, STATE, OR FEDERAL LAWS.
- (10) NO OUTSTANDING BACK TAXES, FINES, JUDGMENTS, OR LIENS ARE OWED TO THE CITY.
- (11) COMPLIANCE OF DEVELOPER WITH THE PROVISIONS CONTAINED IN CHAPTER 2, ARTICLE V, SEC. 2-19.2 OF THE FLINT CODE OF ORDINANCES, REGARDING DISCRIMINATORY PRACTICES.
- (12) PROVIDE FOR THE CLEANUP OF CONTAMINATION ON SITE, AS REQUIRED BY THE MICHIGAN DEPARTMENT OF ENVIRONMENTAL QUALITY.
- (13) THE REQUIREMENTS OF THIS ORDINANCE MAY BE WAIVED BY RESOLUTION OF THE CITY COUNCIL UPON SUBMISSION BY EITHER THE DIRECTOR OF BUSINESS AND COMMUNITY SERVICES OR THE DEVELOPER IDENTIFYING REASONS THAT THE REQUIREMENTS OF THIS ORDINANCE ARE IMPRACTICAL OR INFEASIBLE AND IDENTIFYING HOW THE DEVELOPER WILL PROVIDE COMMUNITY BENEFITS.

- (14) ANY HOUSING PROJECT THAT RECEIVES AN APPROVED PILOT FOR SERVICING PERSONS OF LOW AND MODERATE INCOME WHO MEET THE IDENTIFIED AND DEMONSTRABLE NEED FOR CREATING OR PRESERVING 50% OF THE PROJECT'S TOTAL HOUSING UNITS FOR AFFORDABLE HOUSING, MAY BE EXEMPT FROM A COMMUNITY BENEFITS AGREEMENT UPON THE APPROVAL OF THE FLINT CITY COUNSEL.

§25-4. COMMUNITY ENGAGEMENT PROCESS.

THE DIRECTOR AND THE CITYWIDE ADVISORY COMMITTEE WILL DEVELOP AN APPLICATION PROCESS TO CREATE A POOL OF CANDIDATES FROM THE IMPACTED AREA TO ASSIST THE CITYWIDE ADVISORY COUNCIL IN NEGOTIATING A COMMUNITY BENEFITS AGREEMENT FOR THAT PROJECT. THIS POOL WILL BECOME PART OF THE REGISTERED GROUP AS DEFINED IN SECTION 25-2 OF THIS ORDINANCE. THE OFFICE OF BUSINESS AND COMMUNITY SERVICES SHALL KEEP THIS INFORMATION ON FILE. THE REGISTERED GROUP SHALL BE RESPONSIBLE FOR THE ACCURACY OF THE INFORMATION SUBMITTED TO THE OFFICE OF BUSINESS AND COMMUNITY DEVELOPMENT.

- (1) THE DIRECTOR WILL SELECT TWO (2) RESIDENTS FROM THE POOL OF APPLICANTS FROM THE IMPACTED AREA.**
- (2) IF THE DIRECTOR RECEIVES LESS THAN THREE APPLICANTS, THE DIRECTOR OF BUSINESS AND COMMUNITY SERVICES MAY SEEK OUT ADDITIONAL APPLICATIONS FROM INDIVIDUALS THAT LIVE OUTSIDE THE IMPACTED AREA.**
- (3) THE TWO RESIDENTS NOMINATED BY THE DIRECTOR OF BUSINESS AND COMMUNITY SERVICES MUST BE APPROVED BY A MAJORITY OF THE CITYWIDE ADVISORY COUNCIL.**
- (4) THE TWO RESIDENTS SELECTED WILL SERVE ON THE CITYWIDE ADVISORY COUNCIL UNTIL THE COMPLETION OF THE PROJECT AS DETERMINED BY THE DIRECTOR OF BUSINESS AND COMMUNITY SERVICES AND THE ADVISORY COUNCIL.**

- (5) ALL RESIDENTS OVER THE AGE OF 18 THAT RESIDE IN THE IMPACT AREA ARE ELIGIBLE FOR NOMINATION, PROVIDED THAT, ANY PERSON WHO IS AN AGENT, EMPLOYEE, OR OFFICIAL OF THE DEVELOPER, OR AN EMPLOYEE OF A CITY DEPARTMENT OR AUTHORITY DIRECTLY INVOLVED IN THE DEVELOPMENT, MUST DISCLOSE SUCH RELATIONSHIP PRIOR TO THEIR SELECTION. IF A CONFLICT EXISTS, THE PERSON IS PROHIBITED FROM SERVING ON THE ENFORCEMENT COMMITTEE. A CONFLICT OF INTEREST FOR THIS PURPOSE MEANS ANY FINANCIAL INTEREST HELD PERSONALLY OR BY AN IMMEDIATE FAMILY MEMBER IN THE DEVELOPMENT PROJECT.
- (6) THE CITY CLERK SHALL FORWARD NOTICE OF THE FIRST PUBLIC MEETING VIA FIRST CLASS MAIL NO LESS THAN TEN DAYS BEFORE SUCH MEETING TO ALL CITY OF FLINT RESIDENTS WITHIN THE IMPACT AREA.
- (7) NO MEETING SHALL BE HELD WITH LESS THAN TWO-THIRDS OF THE CITYWIDE ADVISORY COUNCIL PRESENT, NOT INCLUDING MEMBERS SERVING FROM THE IMPACTED AREA. ALL MEETINGS MUST CONFORM TO FEDERAL, STATE, AND LOCAL LAWS THAT GOVERN THE OPEN MEETINGS ACT.
- (8) PRIOR TO SUBMITTING TO CITY COUNCIL, A REQUEST FOR APPROVAL OF LAND TRANSFERS OR TAX ABATEMENTS RELATED TO A TIER 1, TIER 2, OR TIRE 3 PROJECTS, THE DIRECTOR SHALL HOLD NO FEWER THAN FIVE PUBLIC MEETINGS, UNLESS A MAJORITY OF THE CITYWIDE ADVISORY COUNCIL VOTES TO WAIVE ONE OR MORE OF THE REQUIRED MEETINGS, BUT NOT LESS THAN TWO PUBLIC MEETINGS SHALL BE HELD IN ALL CIRCUMSTANCES.
- (9) ALL ACTIONS OF THE CITYWIDE ADVISORY COUNSEL MAY BE TAKEN WITH THE CONSENT OF A MAJORITY OF CITYWIDE ADVISORY COMMITTEE MEMBERS PRESENT, PLUS AT LEAST ONE OF THE TWO MEMBERS SERVING ON THE COMMITTEE, THAT IS PRESENT, OF THE IMPACT AREA.
- (10) IN ADDITION TO THE MEETING REQUIREMENT IN THIS SECTION, THE DIRECTOR SHALL FACILITATE AT LEAST ONE MEETING BETWEEN THE CITYWIDE ADVISORY COUNCIL AND THE DEVELOPER TO ALLOW THE CITYWIDE ADVISORY COUNCIL TO LEARN MORE DETAILS ABOUT THE PROJECT AND TO PROVIDE AN OPPORTUNITY FOR THE CITYWIDE ADVISORY COUNCIL TO MAKE THE DEVELOPER AWARE OF CONCERNS RAISED BY THE RESIDENTS OF THE IMPACTED AREA.

(11) COMMUNITY BENEFITS REPORT AND AGREEMENT: THE DIRECTOR SHALL PROVIDE A COMMUNITY BENEFITS REPORT TO THE CITY COUNCIL REGARDING TIER 1, TIER 2, AND TIER3 PROJECTS PRIOR TO THE REQUEST FOR ANY APPROVALS RELATED TO THOSE PROJECTS.

THE COMMUNITY BENEFITS REPORT SHALL CONTAIN:

- A. A DETAILED ACCOUNT OF HOW NOTICE WAS PROVIDED TO ORGANIZE THE PUBLIC MEETING.**
- B. A LIST OF CANDIDATES SELECTED FROM THE IMPACT AREA TO ASSIST THE CITYWIDE ADVISORY COUNCIL MEMBERS AND HOW THEY WERE SELECTED.**
- C. AN ITEMIZED LIST OF THE CONCERNS RAISED BY THE CITYWIDE ADVISORY COUNCIL.**
- D. A METHOD FOR ADDRESSING EACH OF THE CONCERNS RAISED BY THE CITYWIDE ADVISORY COUNCIL OR WHY A PARTICULAR CONCERN WILL NOT BE ADDRESSED; AND**
- E. A DETAILED LIST OF COMMUNITY OUTREACH STRATEGIES, INCLUSIVE OF A LANGUAGE ACCESS PLAN, THAT HAVE BEEN USED TO SOLICIT AND RECORD FEEDBACK.**
- F. THE DIRECTOR, WHERE POSSIBLE, SHALL PROVIDE A COPY OF THE COMMUNITY BENEFITS REPORT TO THE CITYWIDE ADVISORY COUNCIL PRIOR TO SUBMISSION TO THE CITY COUNCIL.**
- G. THE CITYWIDE ADVISORY COUNCIL SHALL HAVE AT LEAST ONE WEEK TO REVIEW THE COMMUNITY BENEFITS AGREEMENT PRIOR TO RECEIVING A REQUEST FROM THE DEVELOPER TO EITHER VOTE TO APPROVE OR SIGN A LETTER IN SUPPORT OF THE PROPOSED BENEFITS PROVIDED THAT, IF A MAJORITY OF THE CITYWIDE ADVISORY COUNCIL VOTES AGAINST THE PROPOSAL, THEN ADDITIONAL TIME SHALL BE PROVIDED FOR DISCUSSION AND NEGOTIATION.**
- H. THE DIRECTOR SHALL WORK WITH THE CITY COUNCIL TO ASSURE THAT, TO THE MAXIMUM EXTENT POSSIBLE, ALL APPROVALS REQUIRED OF THE CITY COUNCIL MAY BE CONSIDERED SIMUTANEOUSLY AND SUBJECT TO ONE APPROVAL VOTE.**
- I. THE DIRECTOR WORK WITH OTHER CITY DEPARTMENTS TO FACILLITATE THAT ALL PROJECTS RECEIVE EXPEDITED CITY-REQUIRED APPROVAL.**

§25-5. DEVELOPMENT AGREEMENT.

ALL DEVELOPMENT AGREEMENTS MADE BETWEEN THE DEVELOPER AND THE CITY RELATED TO THE LAND TRANSFERS OR TAX ABATEMENTS ASSOCIATED WITH A TIER 1, TIER 2, OR TIER 3 PROJECTS SHALL INCLUDE THE COMMUNITY BENEFITS PROVISION, WHICH SHALL INCLUDE:

- (1) ENFORCEMENT MECHANISMS FOR FAILURE TO ADHERE TO COMMUNITY BENEFITS PROVISIONS, THAT MAY INCLUDE BUT ARE NOT LIMITED TO, CLAW BACK OF CITY-PROVIDED BENEFITS, REVOCATION OF LAND TRANSFERS OR LAND SALES, DEBARMENT PROVISIONS AND PROPORTIONATE PENALTIES AND FEES.**
- (2) THE PROCEDURE FOR COMMUNITY MEMBERS TO REPORT VIOLATIONS OF THE COMMUNITY BENEFITS PROVISION TO THE ENFORCEMENT COMMITTEE.**
- (3) THE LENGTH OF TIME THAT ANNUAL COMPLIANCE REPORTS WILL BE SUBMITTED TO THE CITYWIDE ADVISORY COMMITTEE.**
- (4) CONTINUED COMMUNITY ENGAGEMENT OR COMMUNITY MEETING REQUIREMENTS.**
- (5) THE DEVELOPER SHALL NOT BE REQUIRED TO ENTER INTO A LEGALLY BINDING AGREEMENT WITH ANY INDIVIDUAL OR ORGANIZATION OTHER THAN THE CITY FOR THE EXPRESS PURPOSE OF FULFILLING THE REQUIREMENTS OF THIS ORDINANCE OR OTHER CITY-MANDATED COMMUNITY ENGAGEMENT PROCESS.**

§25-6. STANDARDS.

THE FOLLOWING MINIMUM STANDARDS SHALL BE REQUIRED OF ANY COMMUNITY BENEFITS AGREEMENT:

- (1) LEGALLY ENFORCEABLE AND THE RESULT OF THE PROCEDURE SPECIFIED.**
- (2) THE COMMUNITY BENEFITS PROVIDED REFLECT THE SCALE OF AND BE IN PROPORTION TO THE PUBLIC SUPPORT APPROVED.**
- (3) IDENTIFY SPECIFIC METHODS REGARDING MONITORING AND COMPLIANCE WITH THE PROVISIONS OF THE COMMUNITY BENEFITS AGREEMENT.**
- (4) PROVIDE FOR ENFORCEMENT TERMS AND SPECIFIC REMEDIES UPON THE BREACH OR NONCOMPLIANCE OF A PARTY. SUCH REMEDIES MAY INCLUDE, WITHOUT LIMITATION, SPECIFIC PERFORMANCE, LIQUIDATED DAMAGES, CLAW BACKS, OR REVOCATION OR WITHDRAWAL OF PUBLIC SUPPORT.**

- (5) THE PROVISIONS OF A COMMUNITY BENEFITS AGREEMENT SHALL BE BINDING UPON ALL PARTIES, INCLUDING THEIR AGENTS, SUCCESSORS, AND ASSIGNS. AFTER APPROVAL AND EXECUTION BY THE PARTIES, COMMUNITY BENEFITS AGREEMENTS SHALL BE RECORDED AGAINST THE PROPERTY IN WHICH A PROJECT IS LOCATED AND RUN WITH THE LAND.
- (6) INCLUSION OF LOCAL SMALL BUSINESSES, MINORITY-OWNED BUSINESS ENTERPRISES, WOMEN OWNED BUSINESS ENTERPRISES, AND OTHER RELEVANT BUSINESS ORGANIZATIONS IN PRE-BID MEETINGS AND CONFERENCES WITH ADVANCE NOTICE.
- (7) THE DEVELOPER SHALL PROMOTE THE HIRING, TRAINING AND EMPLOYABILITY OF CITY OF FLINT RESIDENTS CONSISTENT WITH THE CITY OF FLINT, STATE, AND FEDERAL LAW
- (8) THE DEVELOPER WILL PAY WAGES CONSISTENT WITH THE HOUSING AND URBAN DEVELOPMENT ACT OF 1968, AS AMENDED BY THE HOUSING AND COMMUNITY DEVELOPMENT ACT OF 1992 (SECTION 3) WHERE FUNDING IS DERIVED FROM THIS AGENCY BY THE CITY OF FLINT, DEVELOPER, ANY THIRD PARTY ENGAGED IN THE PROJECT.
- (9) NO OUTSTANDING PAYMENTS, BACK TAXES, FINES, OR LIENS ARE OWED TO THE CITY OF FLINT.
- (10) PROVIDE FOR THE CLEANUP OF CONTAMINATION ON SITE, AS REQUIRED BY THE MICHIGAN DEPARTMENT OF ENVIRONMENTAL QUALITY.

§25-7. ENFORCEMENT.

AN ENFORCEMENT COMMITTEE SHALL BE ESTABLISHED TO MONITOR TIER 1, TIER 2, AND TIER 3 PROJECTS AND SHALL BE COMPRISED OF, AT MINIMUM, THE FOLLOWING INDIVIDUALS:

- (1) THE CITY ATTORNEY FOR THE CITY OF FLINT; OR THEIR DESIGNEE.
- (2) A REPRESENTATIVE FROM THE DEPARTMENT OF BUSINESS & COMMUNITY SERVICES.
- (3) A REPRESENTATIVE OF THE CITYWIDE ADVISORY COUNCIL WHO REPRESENTS THE IMPACTED AREA.

- (4) THE DIRECTOR APPLICATIONS TO THE ENFORCEMENT COMMITTEE FROM ANY PERSON THAT RESIDES IN THE IMPACTED AREA TO SERVE THROUGHOUT THE DEVELOPMENT PROCESS WHO ARE PRESENT AT THE INITIAL PUBLIC MEETING.
- (5) THE DIRECTOR, THE CITYWIDE ADVISORY COUNCIL MEMBER, AND THE CITY ATTORNEY OR THEIR DESIGNEE, WILL JOINTLY SELECT ONE (1) RESIDENT FROM THE IMPACTED AREA TO SERVE ON THE ENFORCEMENT COMMITTEE.
- (6) IN ADDITION TO THE MEMBERS OF THE ENFORCEMENT COMMITTEE AS IDENTIFIED IN THIS SECTION, THE DIRECTOR REQUIRE THAT OTHER DEPARTMENTS PARTICIPATE IN THE ENFORCEMENT COMMITTEE AS NEEDED.
- (7) THE ENFORCEMENT COMMITTEE SHALL PROVIDE A BIENNIAL COMPLIANCE REPORT TO THE CITY COUNCIL AND THE CITYWIDE ADVISORY COUNCIL FOR THE TIME IDENTIFIED IN THE COMMUNITY BENEFITS PROVISION.
- (8) THE DIRECTOR FACILITATE AT LEAST TWO MEETINGS PER CALENDAR YEAR BETWEEN THE NEIGHBORHOOD ADVISORY COUNCIL AND THE DEVELOPER TO DISCUSS THE STATUS OF TIER 1, TIER 2, OR TIER 3 PROJECTS FOR THE TIME IDENTIFIED IN THE COMMUNITY BENEFITS AGREEMENT.
- (9) THE CITYWIDE ADVISORY COUNCIL SHALL REVIEW ANY ALLEGATIONS OF VIOLATIONS OF THE COMMUNITY BENEFITS PROVISION PROVIDED TO IT BY THE DEVELOPER AND MAY REPORT VIOLATIONS TO THE ENFORCEMENT COMMITTEE IN WRITING.
- (10) UPON RECEIPT OF WRITTEN NOTIFICATION OF ALLEGATIONS OF VIOLATION FROM THE CITYWIDE ADVISORY COUNCIL, THE ENFORCEMENT COMMITTEE SHALL INVESTIGATE SUCH ALLEGATIONS AND SHALL PRESENT THEIR WRITTEN FINDINGS TO THE CITYWIDE ADVISORY COUNCIL BASED UPON THE FOLLOWING:
 - (A) WHETHER THE DEVELOPER IS IN COMPLIANCE WITH THE COMMUNITY BENEFITS PROVISION(S).
 - (B) HOW THE COMMUNITY BENEFITS PROVISION(S) WILL BE ENFORCED OR HOW VIOLATIONS WILL BE MITIGATED.

(C) THE FINDINGS OF THE ENFORCEMENT COMMITTEE SHALL BE PRESENTED TO THE NEIGHBORHOOD ADVISORY COUNCIL NO LATER THAN 21 DAYS FROM THE DATE THE VIOLATIONS WERE REPORTED TO THE ENFORCEMENT COMMITTEE UNLESS THE NEED FOR ADDITIONAL TIME IS REPORTED TO CITY COUNCIL AND THE NEIGHBORHOOD ADVISORY COMMITTEE WITHIN THE ORIGINAL 21-DAY TIME FRAME.

(D) THE DIRECTOR SUBMIT THE ENFORCEMENT COMMITTEE'S REPORT TO THE CITY COUNCIL WITHIN 14 DAYS UNLESS MORE TIME IS GRANTED BY THE CITY COUNCIL.

SEVERABILITY: IF ANY CLAUSE, SENTENCE, SECTION, PARAGRAPH, OR PART OF THIS ORDINANCE, OR THE APPLICATION THEREOF TO ANY PERSON, FIRM, CORPORATION, LEGAL ENTITY, OR CIRCUMSTANCES, SHALL BE FOR ANY REASON ADJUDGED BY A COURT OR TRIBUNAL, OF COMPETENT JURISDICTION TO BE UNCONSTITUTIONAL OR INVALID, SUCH JUDGMENT SHALL NOT EFFECT, IMPAIR, OR INVALIDATE THE REMAINDER OF THIS ORDINANCE AND THE APPLICATION OF SUCH PROVISION TO OTHER PERSONS, FIRMS, CORPORATIONS, LEGAL ENTITIES, OR CIRCUMSTANCES BY SUCH JUDGMENT SHALL BE CONFINED IN ITS OPERATION TO THE CLAUSE, SENTENCE, SECTION, PARAGRAPH, OR PART OF THIS ORDINANCE THEREOF DIRECTLY INVOLVED IN THE CASE OR CONTROVERSY IN WHICH SUCH JUDGMENT SHALL HAVE BEEN RENDERED AND TO THE PERSON, FIRM, CORPORATION, LEGAL ENTITY, OR CIRCUMSTANCES THEN AND THERE INVOLVED. IT IS HEREBY DECLARED TO BE THE LEGISLATIVE INTENT OF THIS BODY THAT THE ORDINANCE WOULD HAVE BEEN ADOPTED HAD SUCH INVALID OR UNCONSTITUTIONAL PROVISIONS HAVE NOT BEEN INCLUDED IN THIS ORDINANCE.

SEC. 2. THIS ORDINANCE SHALL BECOME EFFECTIVE THIS
_____, 2024, A.O. giving 30-day effect.

Adopted this ___ day of _____, 2024, A.D.

FOR THE CITY:

For the City Clerk

Sheldon A. Neeley,

Mayor APPROVED AS TO FORM:

Joseph N. Kuptz, Acting City Attorney